

Linear Image Processing and Filtering

- Math of 2-d linear systems
- Separability
- Shift-invariant linear systems, 2-d convolution
- Integral image for fast box-filtering
- 2-d frequency response
- Blurring and sharpening
- Zoneplate
- Image sampling/aliasing
- Wiener filtering
- Nonlinear noise reduction/sharpening

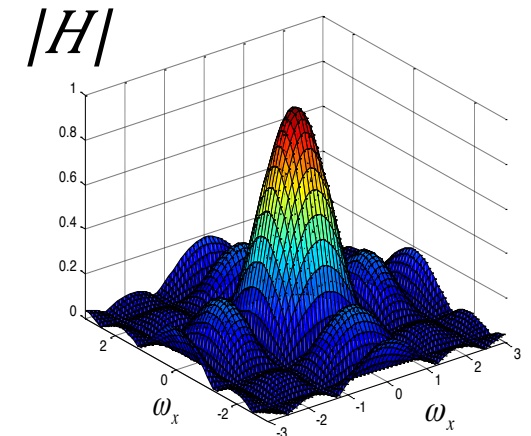
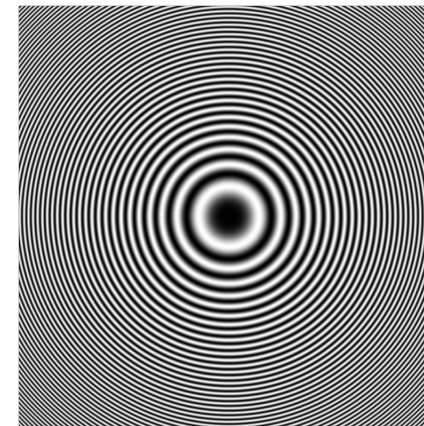

Linear image processing

- Image processing system $S(\cdot)$ is linear, iff superposition principle holds:

$$S\left(\alpha \cdot f[x, y] + \beta \cdot g[x, y]\right) = \alpha \cdot S\left(f[x, y]\right) + \beta \cdot S\left(g[x, y]\right) \quad \text{for all } \alpha, \beta \in \mathbb{R}$$

- Any linear image processing system can be written as

$$\vec{g} = H\vec{f}$$

Note: matrix H need not be square.

by sorting pixels into a column vector

$$\vec{f} = \left(f[0,0] \quad f[1,0] \quad \cdots \quad f[N-1,0] \quad f[0,1] \quad \cdots \quad f[N-1,1] \quad \cdots \quad \cdots \quad f[0,L-1] \quad \cdots \quad f[N-1,L-1] \right)^T$$

Impulse response

- Another way to represent any linear image processing scheme

$$g[\alpha, \beta] = \sum_{x=0}^{N-1} \sum_{y=0}^{L-1} f[x, y] \cdot h[x, \alpha, y, \beta]$$

impulse response

- Input: unit impulse at pixel $[a, b]$

$$f[x, y] = \delta[x - a, y - b] = \begin{cases} 1 & x = a \wedge y = b \\ 0 & \text{else} \end{cases}$$

- Output: impulse response

$$g[\alpha, \beta] = \sum_{x=0}^{N-1} \sum_{y=0}^{L-1} \delta[x - a, y - b] \cdot h[x, \alpha, y, \beta] = h[a, \alpha, b, \beta]$$

Interpretation #1: superposition of impulse responses

$$\delta[x-a, y-b] f[a, b]$$

$$g[\alpha, \beta] = h[a, \alpha, b, \beta] f[a, b]$$

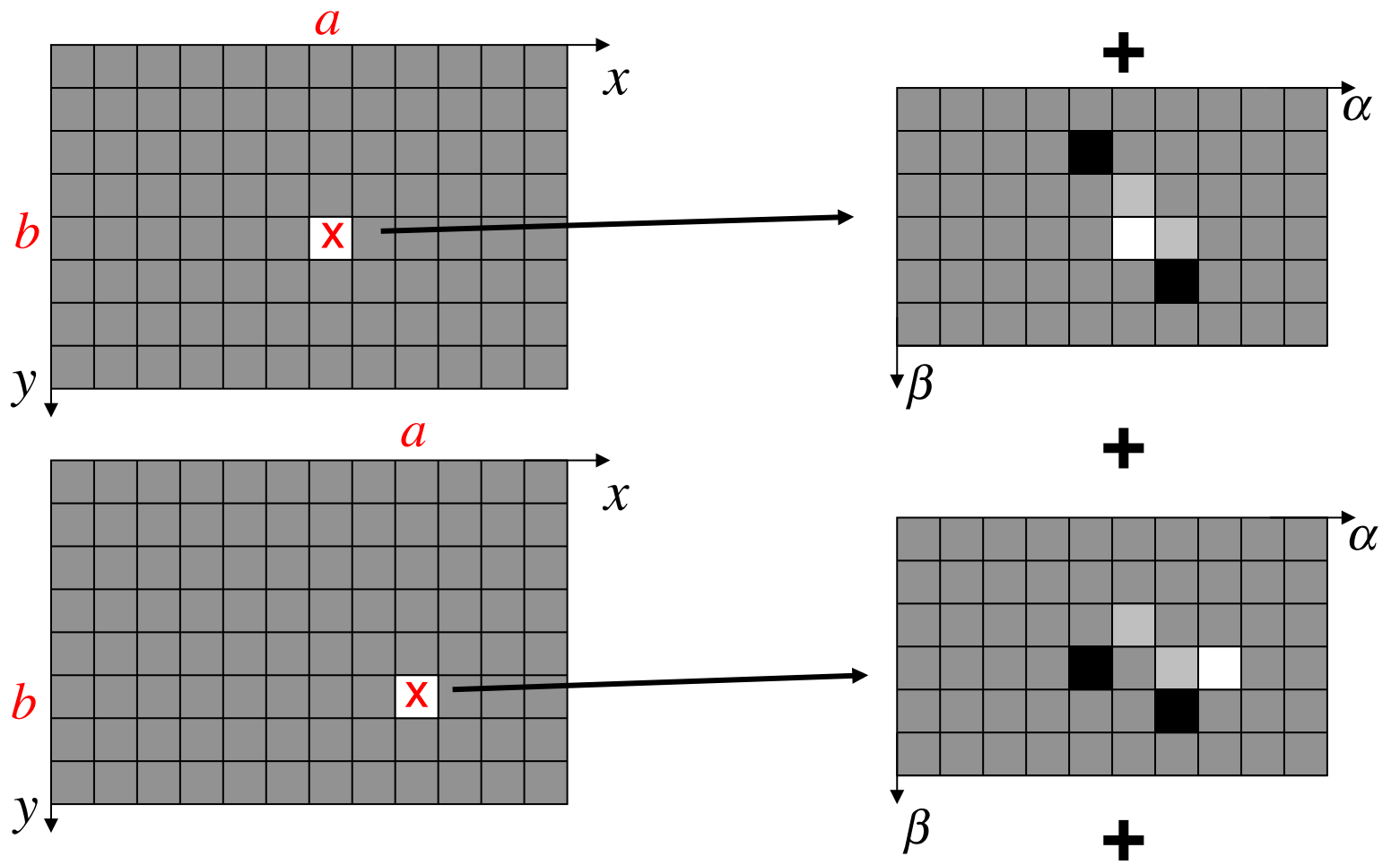

Interpretation #2: linear combination of input values

$$f[x,y] \cdot h[x,\alpha,y,\beta]$$

$$g[\alpha,\beta] = \sum_{x=0}^{N-1} \sum_{y=0}^{L-1} f[x,y] \cdot h[x,\alpha,y,\beta]$$

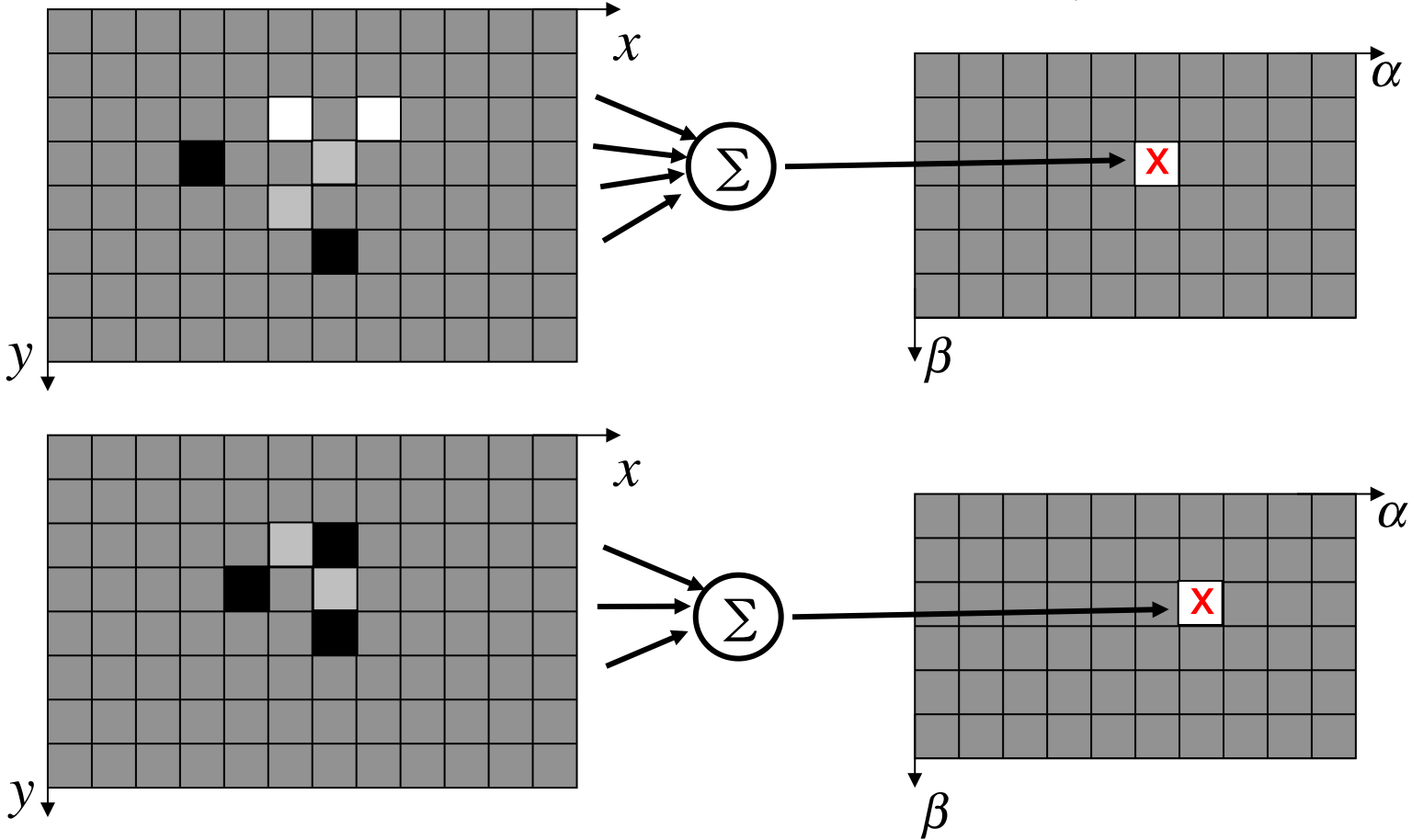

Relationship of H and $h[x, \alpha, y, \beta]$

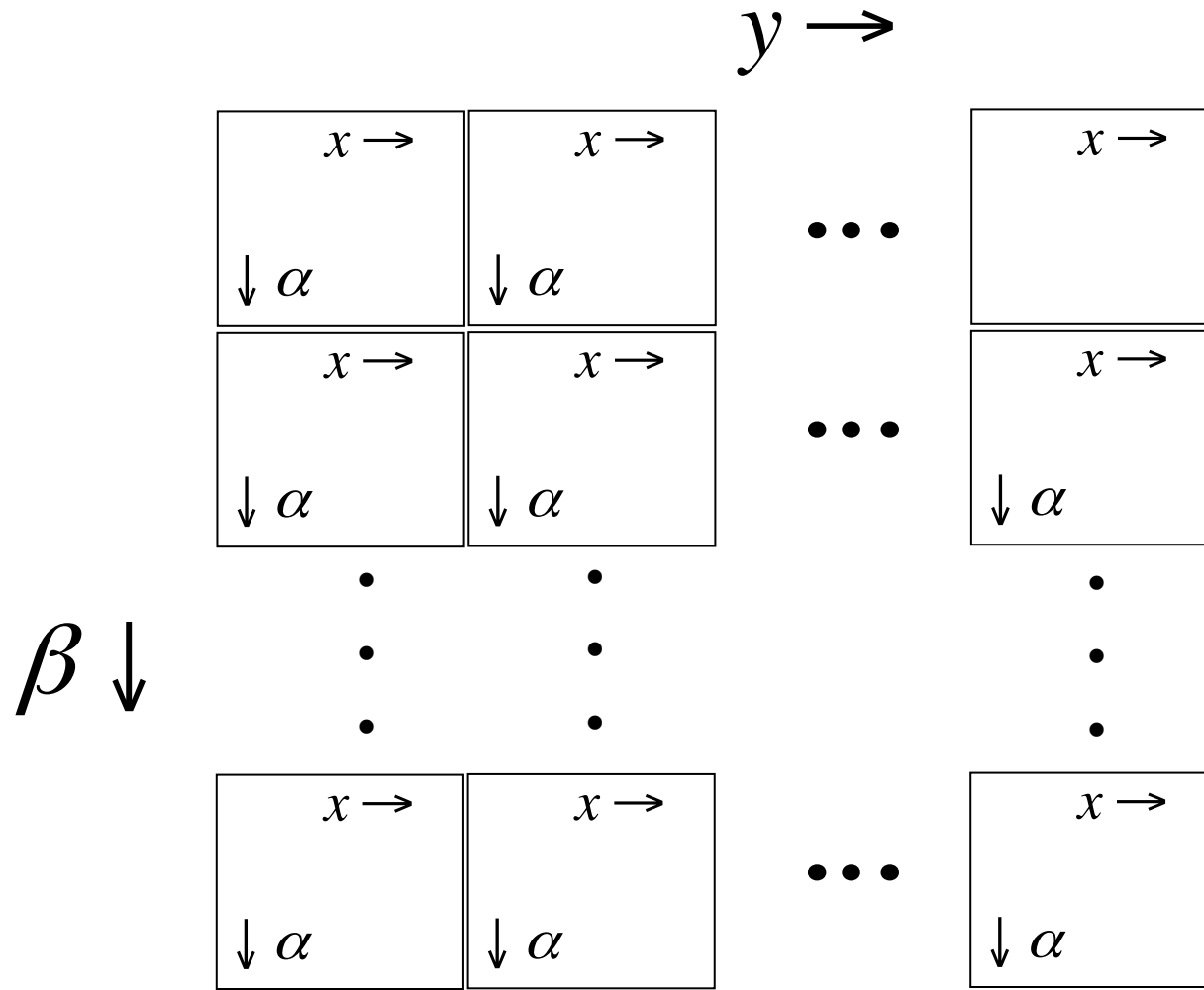

Separable linear image processing

- Impulse response is separable in $[x,\alpha]$ and $[y,\beta]$, i.e., can be written as

$$g[\alpha,\beta] = \sum_{x=0}^{N-1} \sum_{y=0}^{L-1} f[x,y] \cdot h_x[x,\alpha] h_y[y,\beta]$$

- Processing can be carried out
 - row by row, then column by column

$$g[\alpha,\beta] = \sum_{y=0}^{L-1} h_y[y,\beta] \sum_{x=0}^{N-1} f[x,y] \cdot h_x[x,\alpha]$$

- column by column, then row by row

$$g[\alpha,\beta] = \sum_{x=0}^{N-1} h_x[x,\alpha] \sum_{y=0}^{L-1} f[x,y] \cdot h_y[y,\beta]$$

Separable linear image processing (cont.)

- If the digital input and output images are written as a matrices \mathbf{f} and \mathbf{g} , we can conveniently write

$$\mathbf{g} = \mathbf{H}_y^T \cdot \mathbf{f} \cdot \mathbf{H}_x$$
$$\mathbf{H}_y = \begin{bmatrix} h_y[0,0] & h_y[0,1] & \cdots & h_y[0,L_g-1] \\ h_y[1,0] & h_y[1,1] & \cdots & h_y[1,L_g-1] \\ \vdots & \vdots & & \vdots \\ h_y[L-1,0] & h_y[L-1,1] & \cdots & h_y[L-1,L_g-1] \end{bmatrix}$$
$$\mathbf{H}_x = \begin{bmatrix} h_x[0,0] & h_x[0,1] & \cdots & h_x[0,N_g-1] \\ h_x[1,0] & h_x[1,1] & \cdots & h_x[1,N_g-1] \\ \vdots & \vdots & & \vdots \\ h_x[N-1,0] & h_x[N-1,1] & \cdots & h_x[N-1,N_g-1] \end{bmatrix}$$

- Output image \mathbf{g} has size $L_g \times N_g$
- If the operator does not change image size, \mathbf{H}_x and \mathbf{H}_y are square matrices

Example: Separable Haar transform

Original *Bike*
256x256

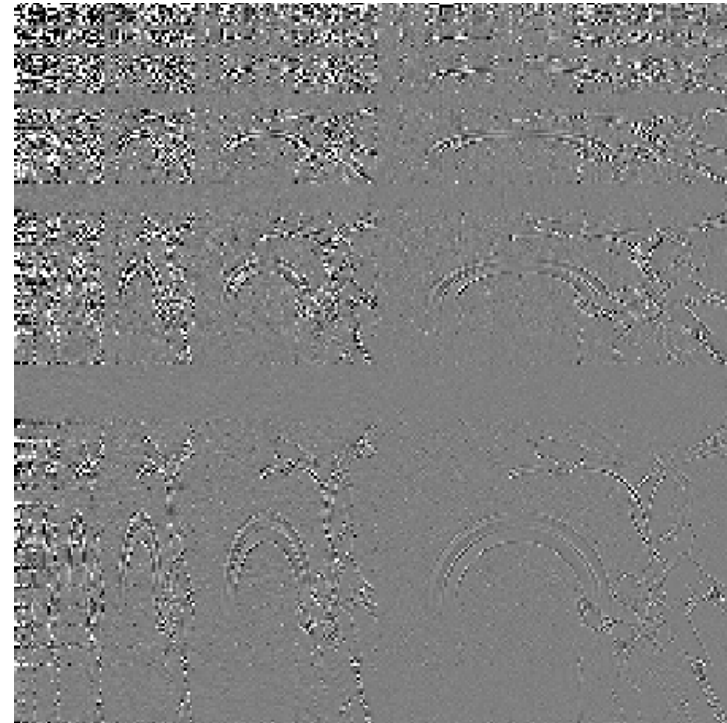

256x256
Haar transform
 $H_x = H_y = H_{r_{256}}$



Haar transform

- Haar transform matrix for sizes $N=2,4,8$

$$\mathbf{Hr}_2 = \frac{1}{\sqrt{2}} \begin{pmatrix} 1 & 1 \\ 1 & -1 \end{pmatrix}$$
$$\mathbf{Hr}_4 = \frac{1}{\sqrt{4}} \begin{pmatrix} 1 & 1 & \sqrt{2} & 0 \\ 1 & 1 & -\sqrt{2} & 0 \\ 1 & -1 & 0 & \sqrt{2} \\ 1 & -1 & 0 & -\sqrt{2} \end{pmatrix}$$
$$\mathbf{Hr}_8 = \frac{1}{\sqrt{8}} \begin{pmatrix} 1 & 1 & \sqrt{2} & 0 & 2 & 0 & 0 & 0 \\ 1 & 1 & \sqrt{2} & 0 & -2 & 0 & 0 & 0 \\ 1 & 1 & -\sqrt{2} & 0 & 0 & 2 & 0 & 0 \\ 1 & 1 & -\sqrt{2} & 0 & 0 & -2 & 0 & 0 \\ 1 & -1 & 0 & \sqrt{2} & 0 & 0 & 2 & 0 \\ 1 & -1 & 0 & \sqrt{2} & 0 & 0 & -2 & 0 \\ 1 & -1 & 0 & -\sqrt{2} & 0 & 0 & 0 & 2 \\ 1 & -1 & 0 & -\sqrt{2} & 0 & 0 & 0 & -2 \end{pmatrix}$$

- Can be computed by taking sums and differences
- Fast algorithms by recursively applying \mathbf{Hr}_2

Example: Subsampling

- Image subsampling 2:1 horizontally and vertically
- Small input image of size 8x8, output image size 4x4

$$\mathbf{H}_x = \mathbf{H}_y = \begin{bmatrix} 1 & 0 & 0 & 0 \\ 0 & 0 & 0 & 0 \\ 0 & 1 & 0 & 0 \\ 0 & 0 & 0 & 0 \\ 0 & 0 & 1 & 0 \\ 0 & 0 & 0 & 0 \\ 0 & 0 & 0 & 1 \\ 0 & 0 & 0 & 0 \end{bmatrix}$$



Example: Subsampling (cont.)

- A somewhat better technique for 2:1 image size reduction

$$\mathbf{H}_x = \mathbf{H}_y = \begin{bmatrix} 0.5 & 0 & 0 & 0 \\ 0.5 & 0 & 0 & 0 \\ 0 & 0.5 & 0 & 0 \\ 0 & 0.5 & 0 & 0 \\ 0 & 0 & 0.5 & 0 \\ 0 & 0 & 0.5 & 0 \\ 0 & 0 & 0 & 0.5 \\ 0 & 0 & 0 & 0.5 \end{bmatrix}$$



Side by side comparison

$$\mathbf{H}_x = \mathbf{H}_y =$$

$$\begin{bmatrix} 1 & 0 & 0 & 0 \\ 0 & 0 & 0 & 0 \\ 0 & 1 & 0 & 0 \\ 0 & 0 & 0 & 0 \\ 0 & 0 & 1 & 0 \\ 0 & 0 & 0 & 0 \\ 0 & 0 & 0 & 1 \\ 0 & 0 & 0 & 0 \end{bmatrix}$$



$$\mathbf{H}_x = \mathbf{H}_y =$$

$$\begin{bmatrix} 0.5 & 0 & 0 & 0 \\ 0.5 & 0 & 0 & 0 \\ 0 & 0.5 & 0 & 0 \\ 0 & 0.5 & 0 & 0 \\ 0 & 0 & 0.5 & 0 \\ 0 & 0 & 0.5 & 0 \\ 0 & 0 & 0 & 0.5 \\ 0 & 0 & 0 & 0.5 \end{bmatrix}$$



Another example: filtering

- Each pixel is replaced by the average of two horizontally (vertically) neighboring pixels

$$\mathbf{H}_x = \mathbf{H}_y = \begin{bmatrix} 0.5 & 0 & & \dots & & & & 0 \\ 0.5 & 0.5 & & & & & & \\ 0 & 0.5 & 0.5 & & & & & \\ & & & 0.5 & 0.5 & \ddots & & \vdots \\ \vdots & & & & 0.5 & 0.5 & & \\ & & & & \ddots & 0.5 & 0.5 & \\ & & & & & & 0.5 & 0.5 & 0 \\ 0 & & & \dots & & & 0 & 0.5 & 0.5 \end{bmatrix}$$

- Shift-invariant operation (except for image boundary)

Shift-invariant systems and Toeplitz matrices

- For a separable, shift-invariant, linear system

$$h_x[x, \alpha] = h_{siv/x}[\alpha - x] \quad \text{and} \quad h_y[y, \beta] = h_{siv/y}[\beta - y]$$

- Matrices \mathbf{H}_x and \mathbf{H}_y are square, and Toeplitz matrices, e.g.,

$$\mathbf{H}_x = \begin{bmatrix} h_{siv/x}[0] & h_{siv/x}[1] & \cdots & h_{siv/x}[N-1] \\ h_{siv/x}[-1] & h_{siv/x}[0] & \cdots & h_{siv/x}[N-2] \\ \vdots & \vdots & \ddots & \vdots \\ h_{siv/x}[1-N] & h_{siv/x}[2-N] & \cdots & h_{siv/x}[0] \end{bmatrix}$$

- Operation is a 2-d separable convolution („filtering“)

$$g[\alpha, \beta] = \sum_{x=0}^{N-1} \sum_{y=0}^{L-1} f[x, y] \cdot h_{siv/x}[\alpha - x] h_{siv/y}[\beta - y]$$

Non-separable 2-d convolution

- Convolution kernel of linear shift-invariant system („filter“) can also be non-separable

$$g[\alpha, \beta] = \sum_{x=0}^{N-1} \sum_{y=0}^{L-1} f[x, y] \cdot h_{siv}[\alpha - x, \beta - y]$$

- Viewed as a matrix operation . . .

$$\vec{g} = H\vec{f}$$

. . . H is a block Toeplitz matrix

Structure of H for non-separable convolution

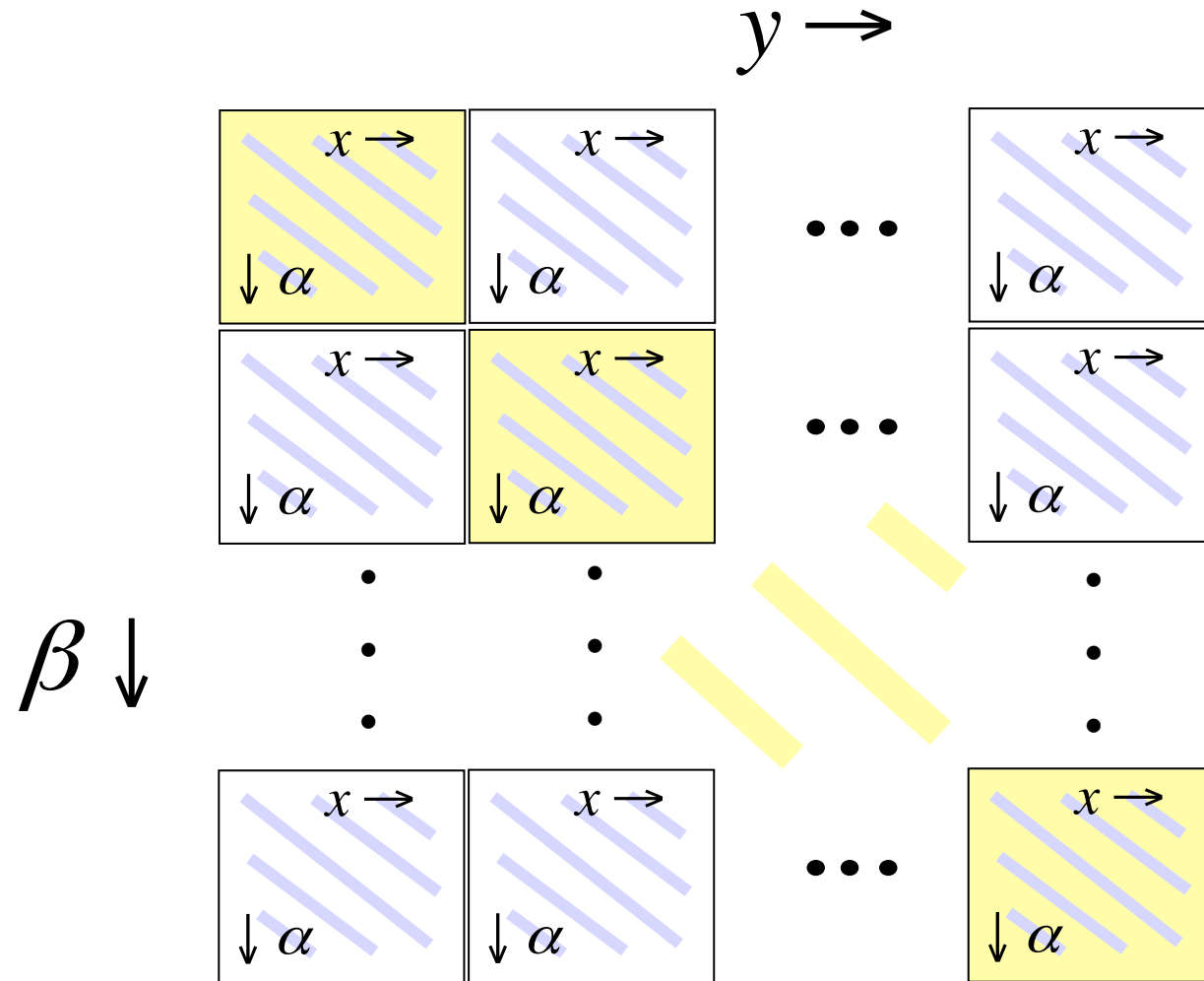

Convolution: superposition of impulse responses

$$f[a,b]\delta[x-a,y-b]$$

$$g[x,y] = h_{siv}[x-a,y-b]f[a,b]$$

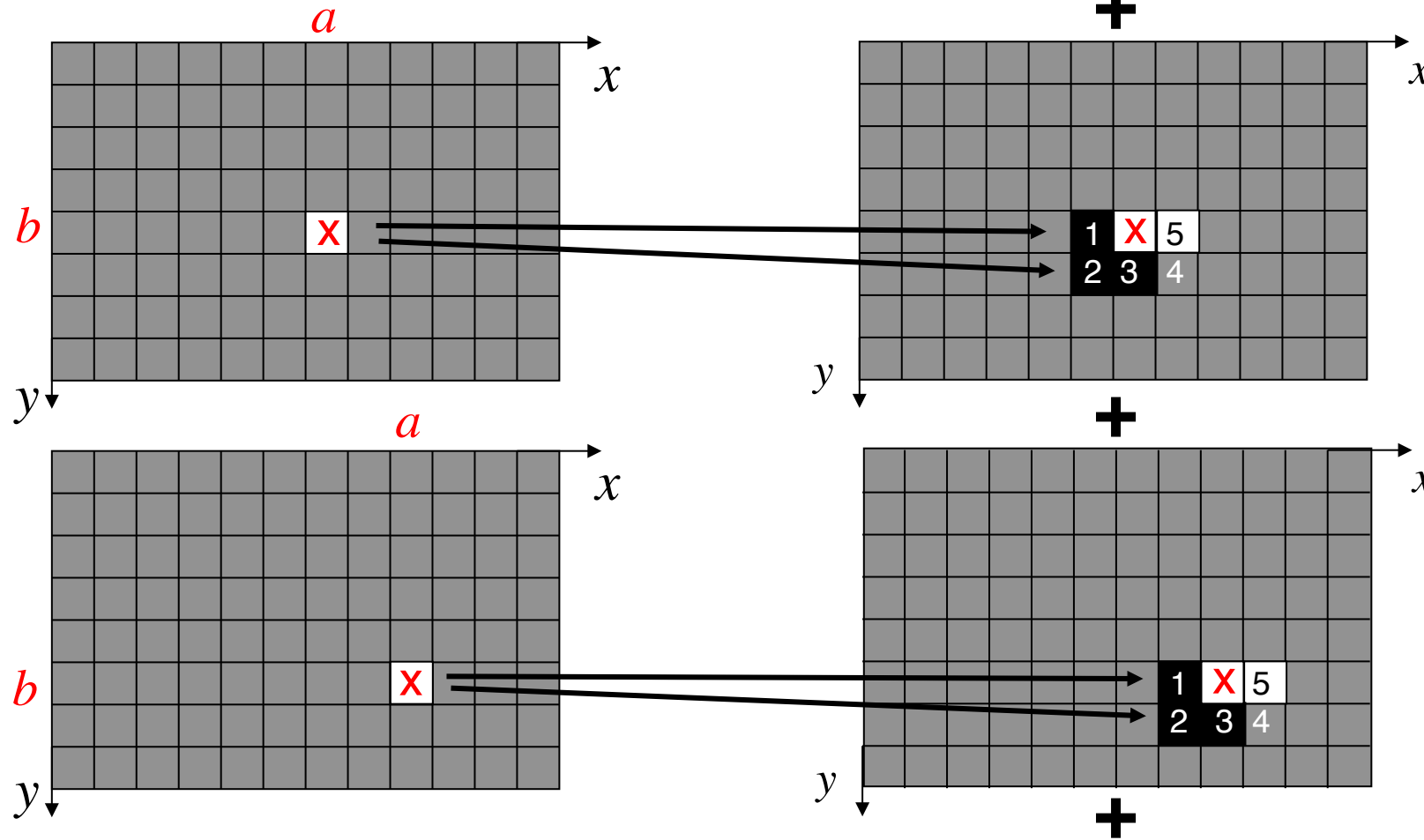

Convolution: linear combination of neighboring pixel values

$$f[x, y] \cdot h_{siv}[\alpha - x, \beta - y]$$

$$g[\alpha, \beta] = \sum_{x=0}^{N-1} \sum_{y=0}^{L-1} f[x, y] \cdot h_{siv}[\alpha - x, \beta - y]$$

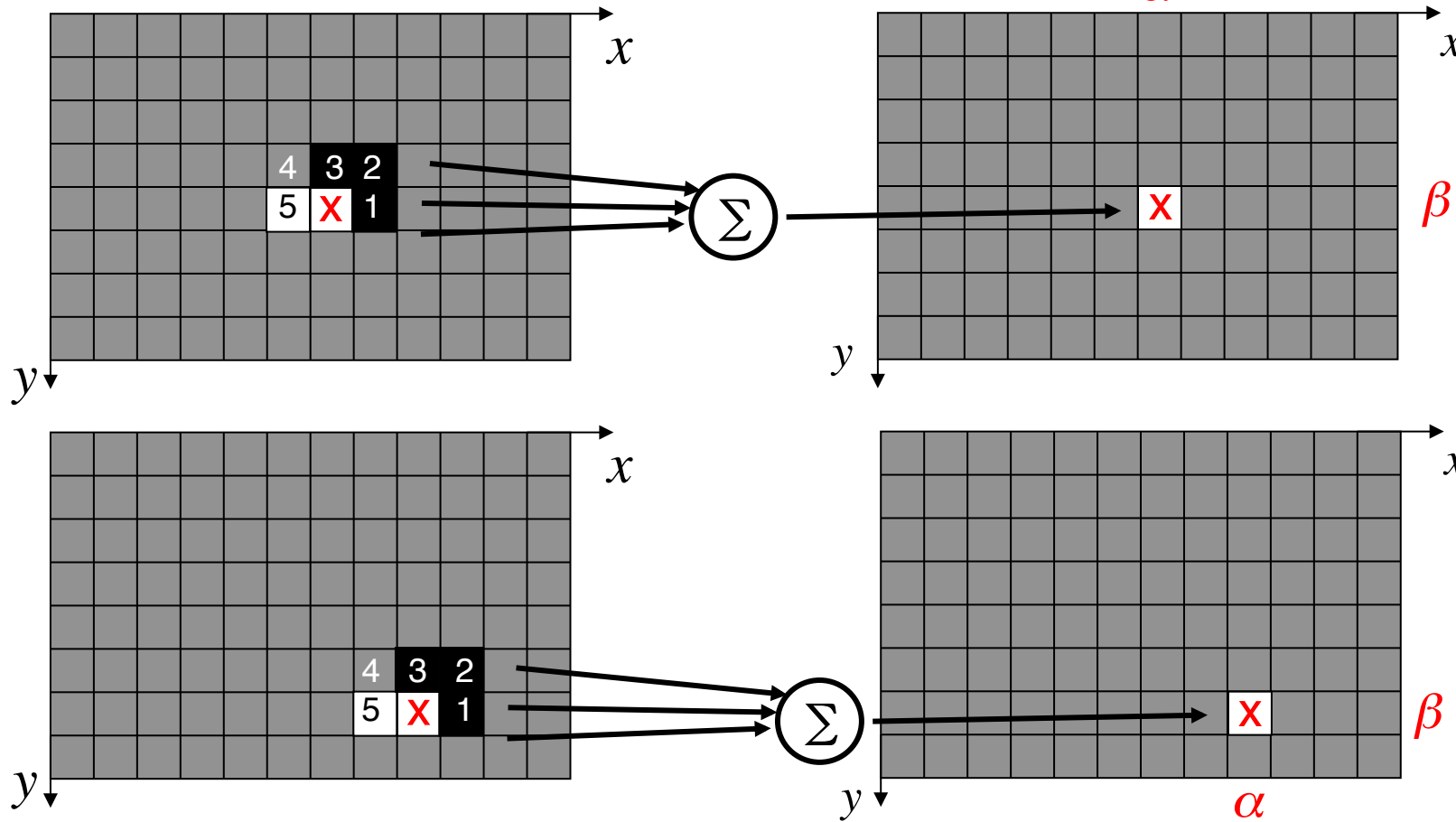

Convolution examples



Original
Bike



Bike blurred by convolution
Impulse response „box filter“

$$\frac{1}{25} \begin{pmatrix} 1 & 1 & 1 & 1 & 1 \\ 1 & 1 & 1 & 1 & 1 \\ 1 & 1 & [1] & 1 & 1 \\ 1 & 1 & 1 & 1 & 1 \\ 1 & 1 & 1 & 1 & 1 \end{pmatrix}$$



Convolution examples



Original
Bike

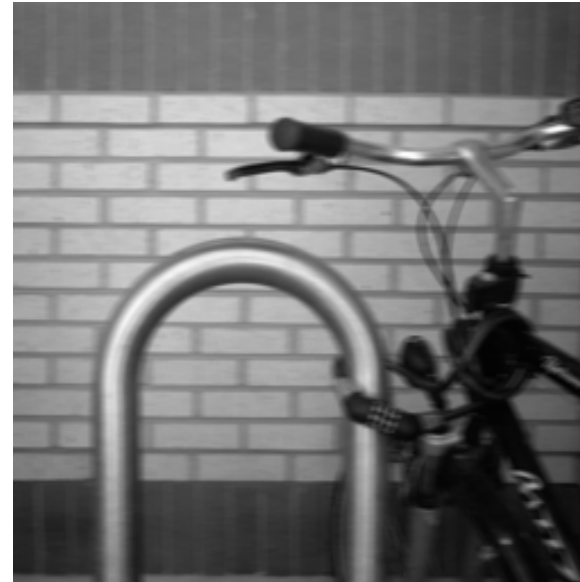

Bike blurred horizontally
Filter impulse response

$$\frac{1}{5} \begin{pmatrix} 1 & 1 & [1] & 1 & 1 \end{pmatrix}$$



Convolution examples



Original
Bike



Bike blurred vertically
Filter impulse response

$$\frac{1}{5} \begin{pmatrix} 1 \\ 1 \\ [1] \\ 1 \\ 1 \end{pmatrix}$$



Integral image

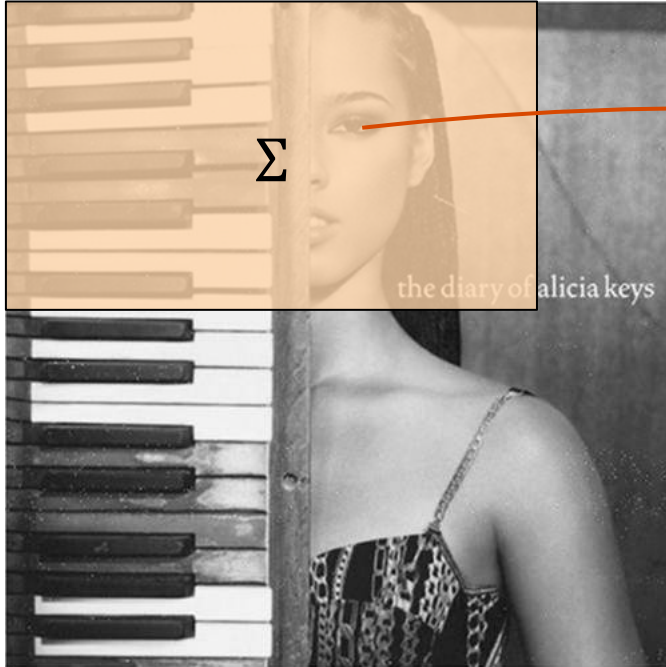

$$f[x, y]$$

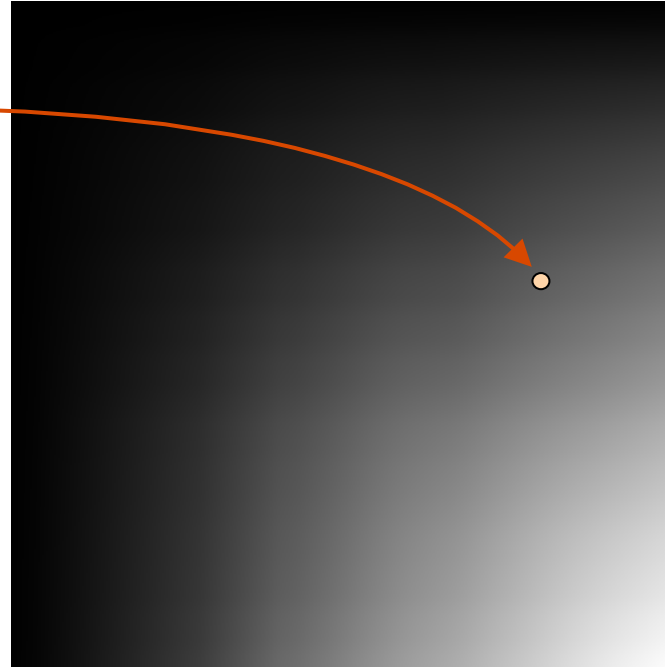

$$i[x, y] = \sum_{u=0}^x \sum_{v=0}^y f[u, v]$$

$$\begin{aligned} j[x, y] &= j[x, y-1] + f[x, y] \\ i[x, y] &= i[x-1, y] + j[x, y] \end{aligned}$$

Box filtering with integral image

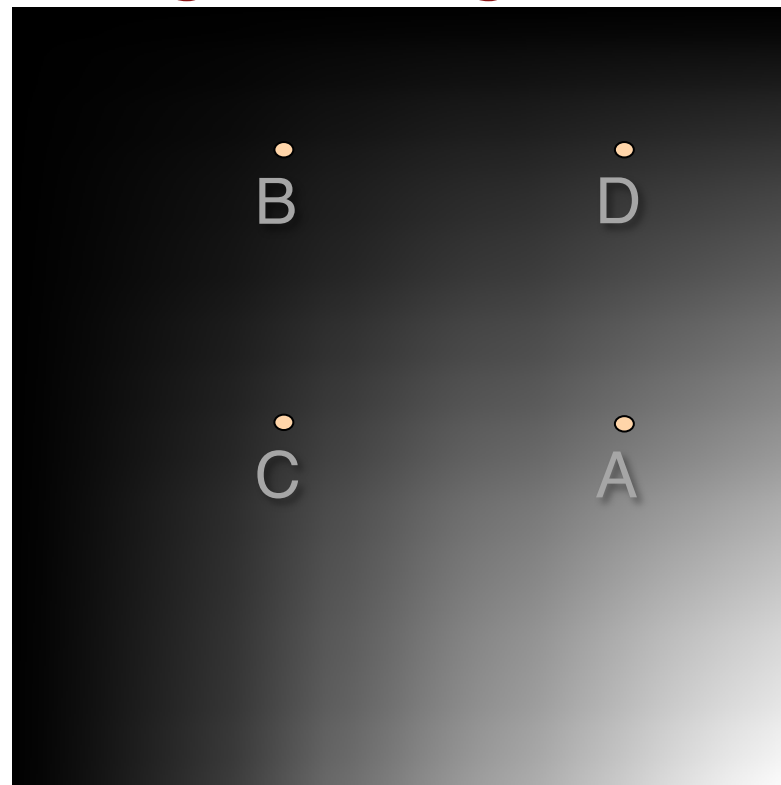
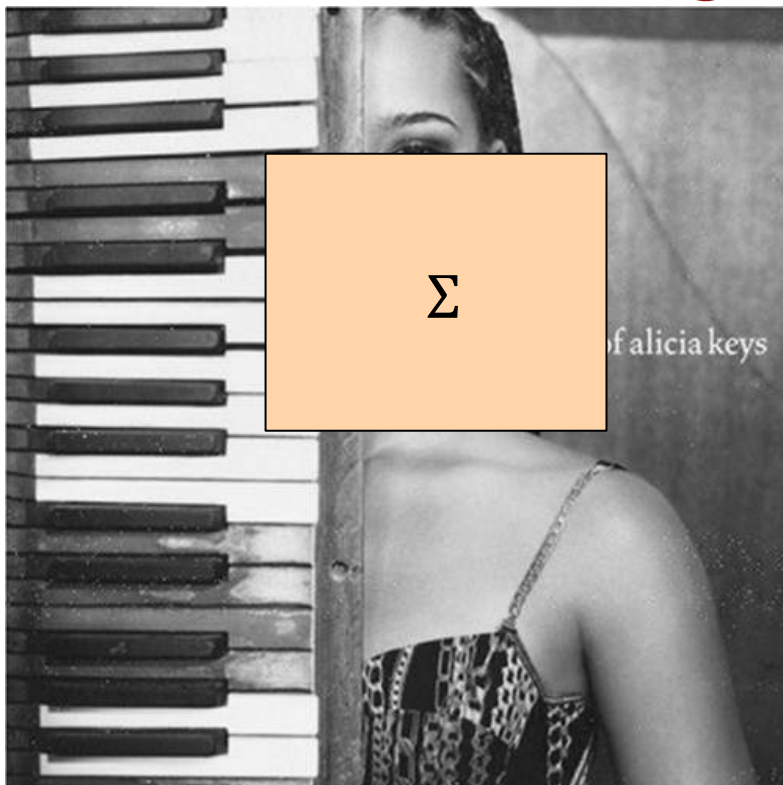

$$\text{Sum} = A + B - C - D$$

Gaussian filtering by repeated box filtering

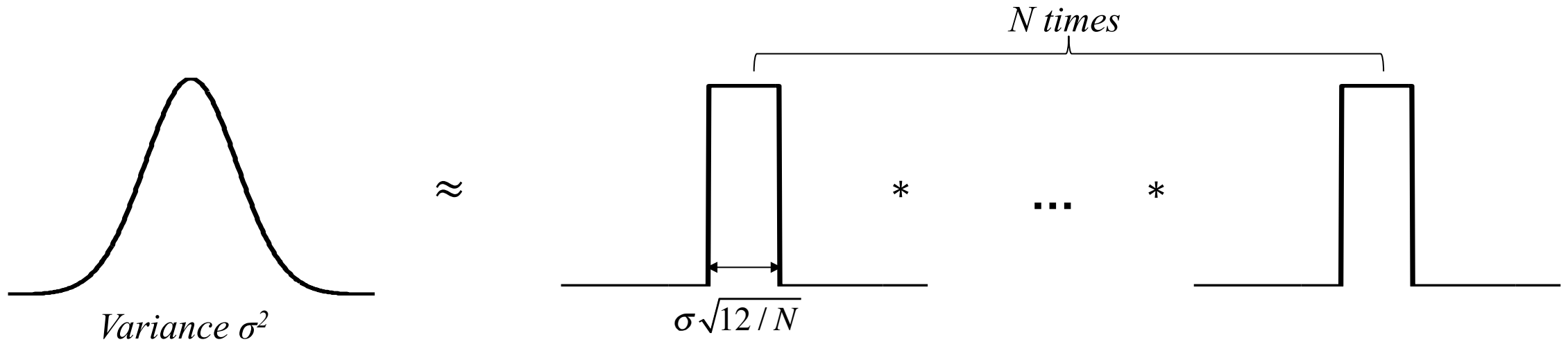

- Approximate convolution with Gaussian kernel by convolution with box kernel, repeated N times
- Convolution with box kernel can be computed efficiently using integral image

Gaussian filtering by repeated box filtering

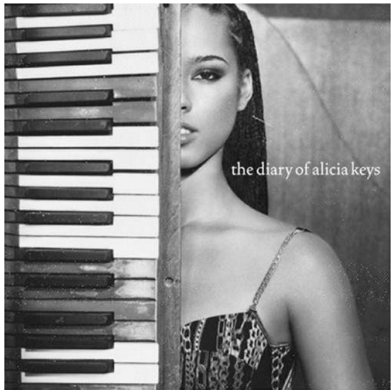

Original image
500x500



Gaussian filtered
 $\sigma = 20$, 81x81 kernel

Direct implementation:
6561 multiplications and
6560 additions per pixel

x-y separable filtering:
162 multiplications and
160 additions per pixel

20 additions or subtractions per pixel



Box filtered
after N = 1

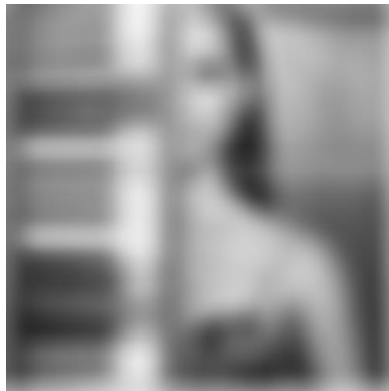

Box filtered
after N = 2

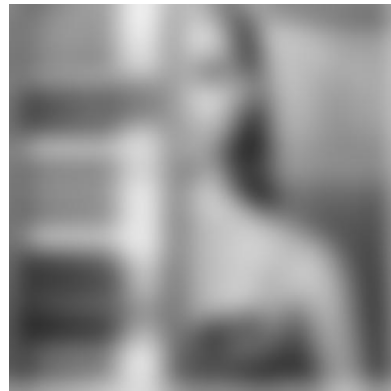

Box filtered
after N = 3

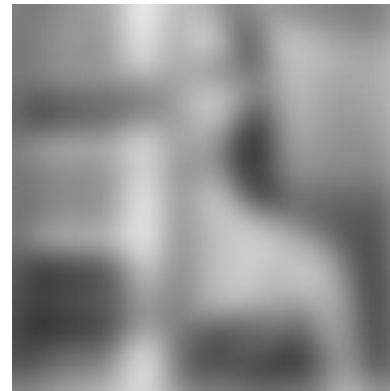

Box filtered
after N = 4



1-d discrete-time Fourier transform

- Given a 1-d sequence $s[k]$, $k \in \mathbf{Z} = \{\dots, -1, 0, 1, 2, 3, \dots\}$
- Fourier transform

$$S(e^{j\omega}) = \sum_{k=-\infty}^{\infty} s[k] e^{-j\omega k} \quad \omega \in \mathfrak{R}$$

- Fourier transform is periodic with 2π
- Inverse Fourier transform

$$s[k] = \frac{1}{2\pi} \int_{-\pi}^{\pi} S(e^{j\omega}) e^{j\omega k} d\omega$$

2-d discrete-space Fourier transform

- Given a 2-d array of image samples

$$s[m, n], \quad m, n \in \mathbf{Z}^2$$

- Fourier transform

$$S(e^{j\omega_x}, e^{j\omega_y}) = \sum_{m=-\infty}^{\infty} \sum_{n=-\infty}^{\infty} s[m, n] e^{-j\omega_x m - j\omega_y n} \quad \omega_x, \omega_y \in \mathfrak{R}^2$$

- Fourier transform is 2π -periodic both in ω_x and ω_y
- Inverse Fourier transform

$$s[m, n] = \frac{1}{4\pi^2} \int_{-\pi}^{\pi} \int_{-\pi}^{\pi} S(e^{j\omega_x}, e^{j\omega_y}) e^{j\omega_x m + j\omega_y n} d\omega_x d\omega_y$$

5x5 box filter revisited



Original
Bike



Bike blurred by convolution
Impulse response „box filter“

$$\frac{1}{25} \begin{pmatrix} 1 & 1 & 1 & 1 & 1 \\ 1 & 1 & 1 & 1 & 1 \\ 1 & 1 & [1] & 1 & 1 \\ 1 & 1 & 1 & 1 & 1 \\ 1 & 1 & 1 & 1 & 1 \end{pmatrix}$$



Frequency response of 5x5 lowpass filter

$$\begin{aligned}
 H(e^{j\omega_x}, e^{j\omega_y}) &= \sum_{m=-\infty}^{\infty} \sum_{n=-\infty}^{\infty} h[m, n] e^{-j\omega_x m - j\omega_y n} \\
 &= \frac{1}{25} \sum_{m=-2}^2 \sum_{n=-2}^2 e^{-j\omega_x m - j\omega_y n} = \frac{1}{25} \sum_{m=-2}^2 e^{-j\omega_x m} \sum_{n=-2}^2 e^{-j\omega_y n} \\
 &= \frac{1}{25} (1 + 2\cos\omega_x + 2\cos(2\omega_x)) (1 + 2\cos\omega_y + 2\cos(2\omega_y))
 \end{aligned}$$

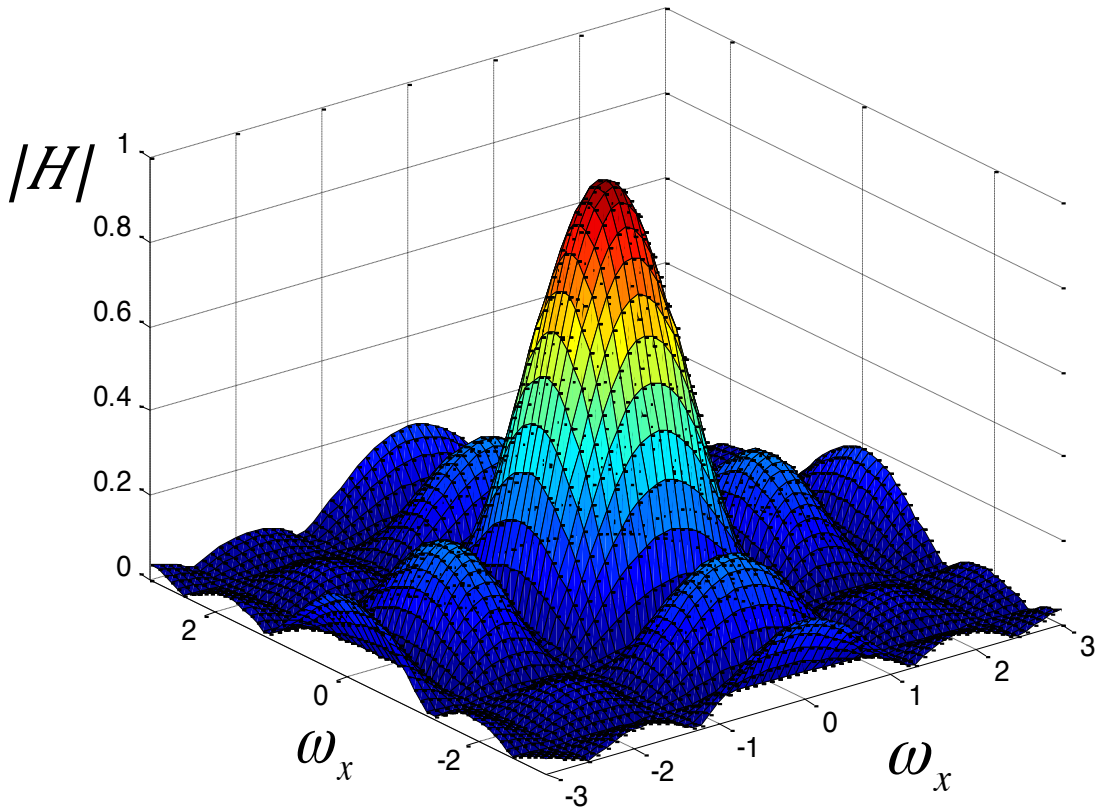

Separable filter:
1-d frequency responses
are multiplied



Horizontal lowpass filter



Bike blurred horizontally

Filter impulse response

$$\frac{1}{5} \begin{pmatrix} 1 & 1 & [1] & 1 & 1 \end{pmatrix}$$

$$H(e^{j\omega_x}, e^{j\omega_y}) = \frac{1}{5} (1 + 2 \cos \omega_x + 2 \cos(2\omega_x))$$

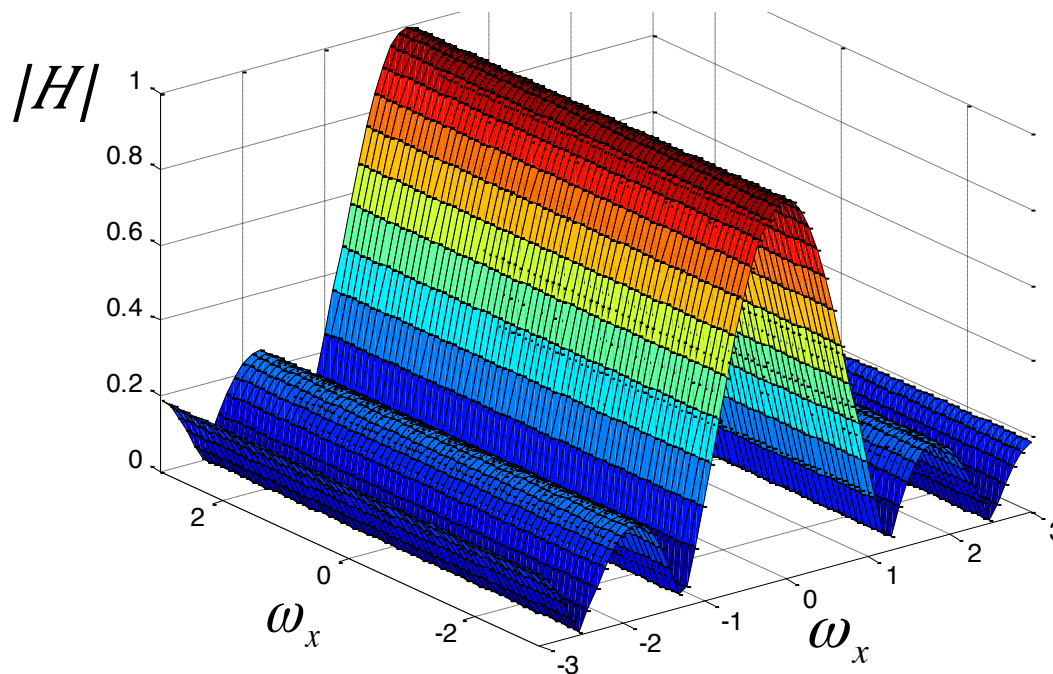

Vertical lowpass filter



Bike blurred vertically
Filter impulse response

$$\frac{1}{5} \begin{pmatrix} 1 \\ 1 \\ [1] \\ 1 \\ 1 \end{pmatrix}$$

$$H(e^{j\omega_x}, e^{j\omega_y}) = \frac{1}{5} (1 + 2\cos\omega_y + 2\cos(2\omega_y))$$

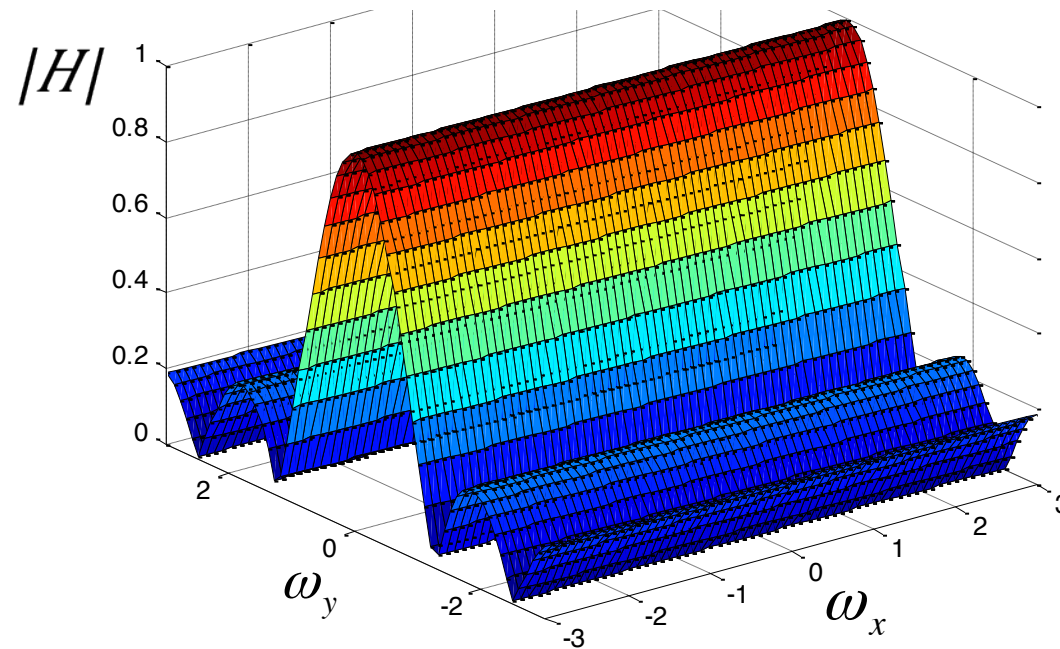

Sharpening filter



Original
Bike



Bike sharpened
Filter impulse response

$$\frac{1}{4} \begin{pmatrix} 0 & -1 & 0 \\ -1 & [8] & -1 \\ 0 & -1 & 0 \end{pmatrix}$$



Frequency response of sharpening filter

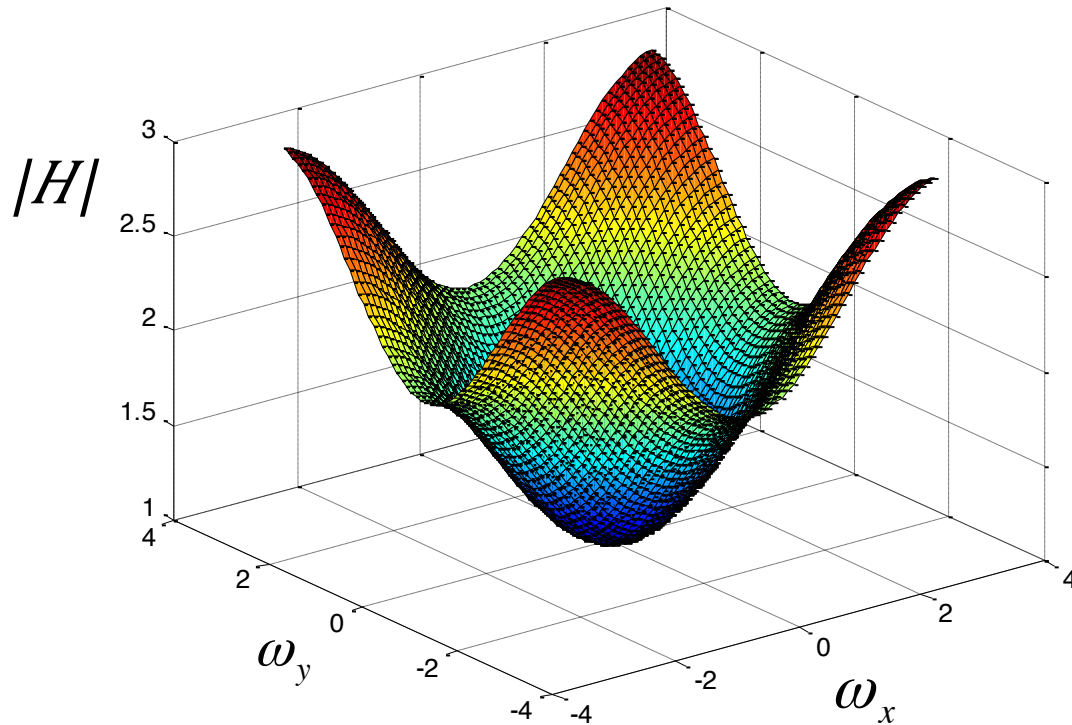

$$\begin{aligned} H(e^{j\omega_x}, e^{j\omega_y}) &= \sum_{m=-\infty}^{\infty} \sum_{n=-\infty}^{\infty} h[m, n] e^{-j\omega_x m - j\omega_y n} \\ &= \frac{1}{4} \left(8 - e^{-j\omega_x} - e^{j\omega_x} - e^{-j\omega_y} - e^{j\omega_y} \right) \\ &= 2 - \frac{1}{2} \cos \omega_x - \frac{1}{2} \cos \omega_y \end{aligned}$$



More aggressive sharpening



Bike sharpened
Filter impulse response

$$\begin{pmatrix} 0 & -1 & 0 \\ -1 & [5] & -1 \\ 0 & -1 & 0 \end{pmatrix}$$

$$H(e^{j\omega_x}, e^{j\omega_y}) = 5 - 2\cos\omega_x - 2\cos\omega_y$$

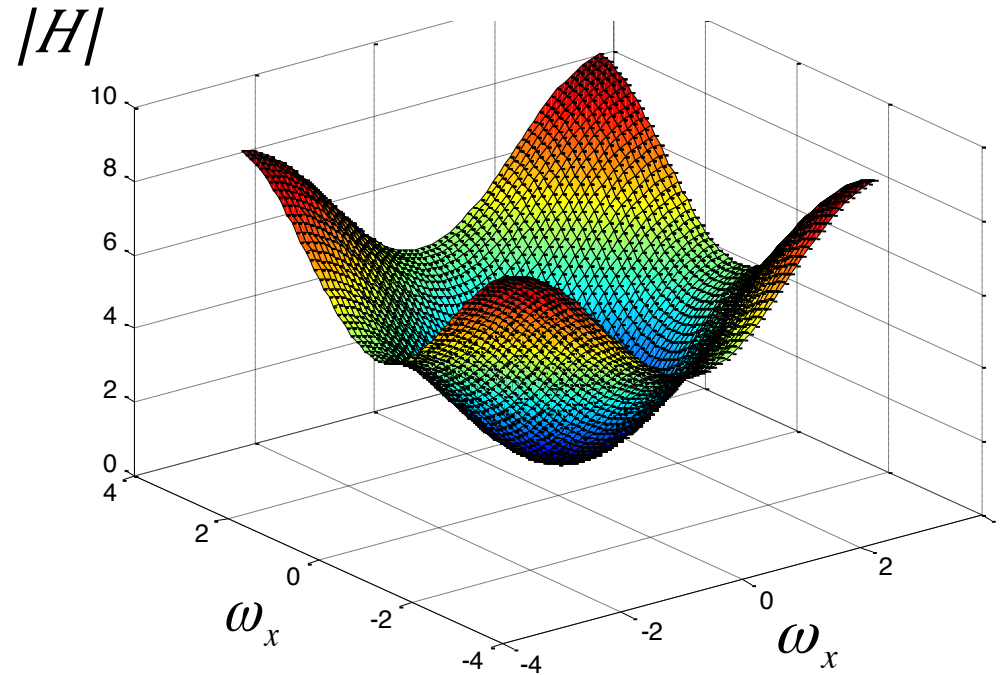

Zoneplate pattern to visualize frequency plane

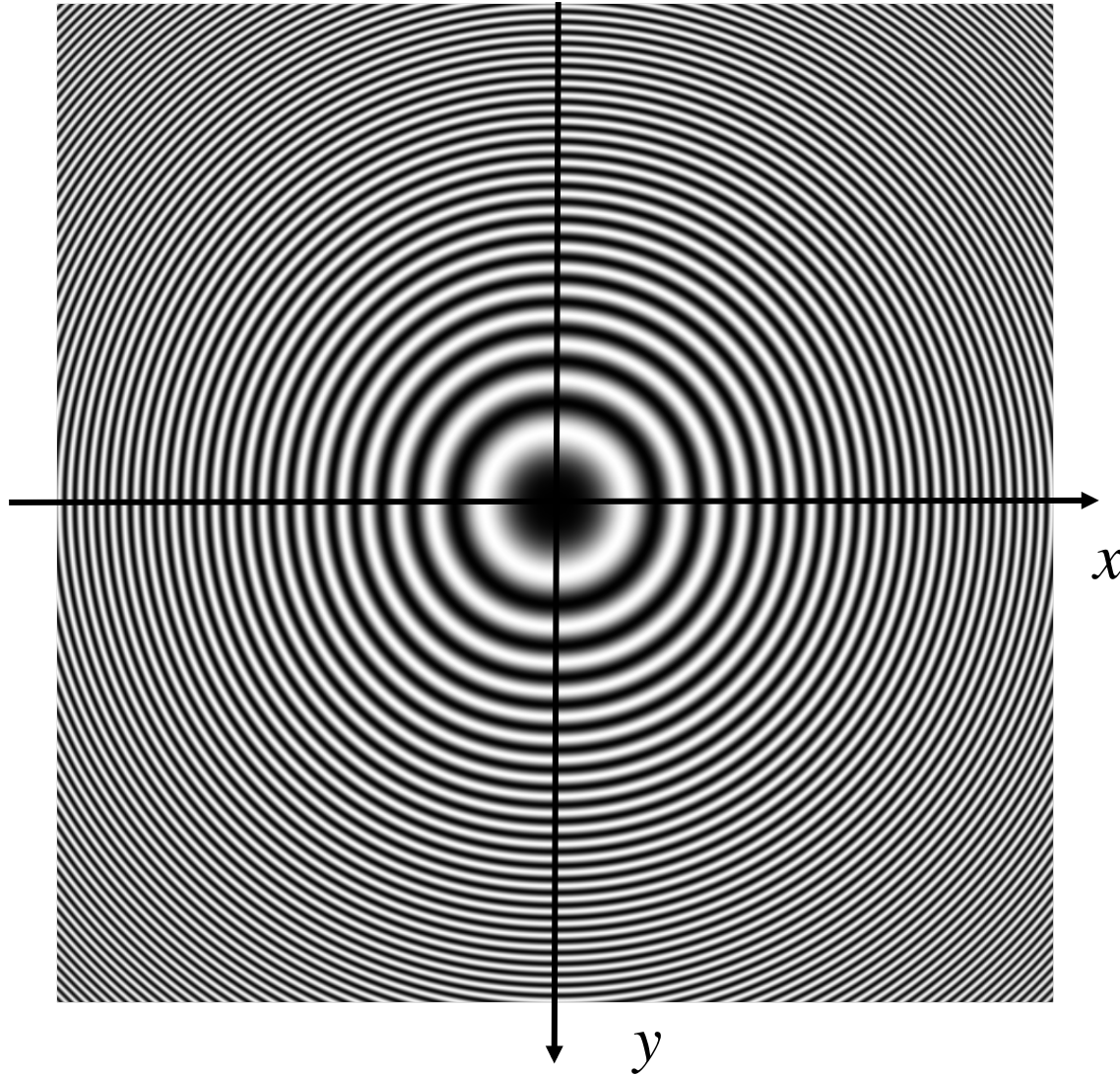

Equation to generate pattern:

$$s(x, y) = \hat{s} \cos(a_x x^2 + a_y y^2) + s_0$$

Local frequency at (x, y)

$$\frac{\partial}{\partial x} (a_x x^2 + a_y y^2) = 2a_x x$$

$$\frac{\partial}{\partial y} (a_x x^2 + a_y y^2) = 2a_y y$$

$$s[x, y] \begin{array}{c} \xrightarrow{\text{interpolation}} \\ \xleftarrow{\text{sampling}} \end{array} s(x, y)$$

Lowpass filtering

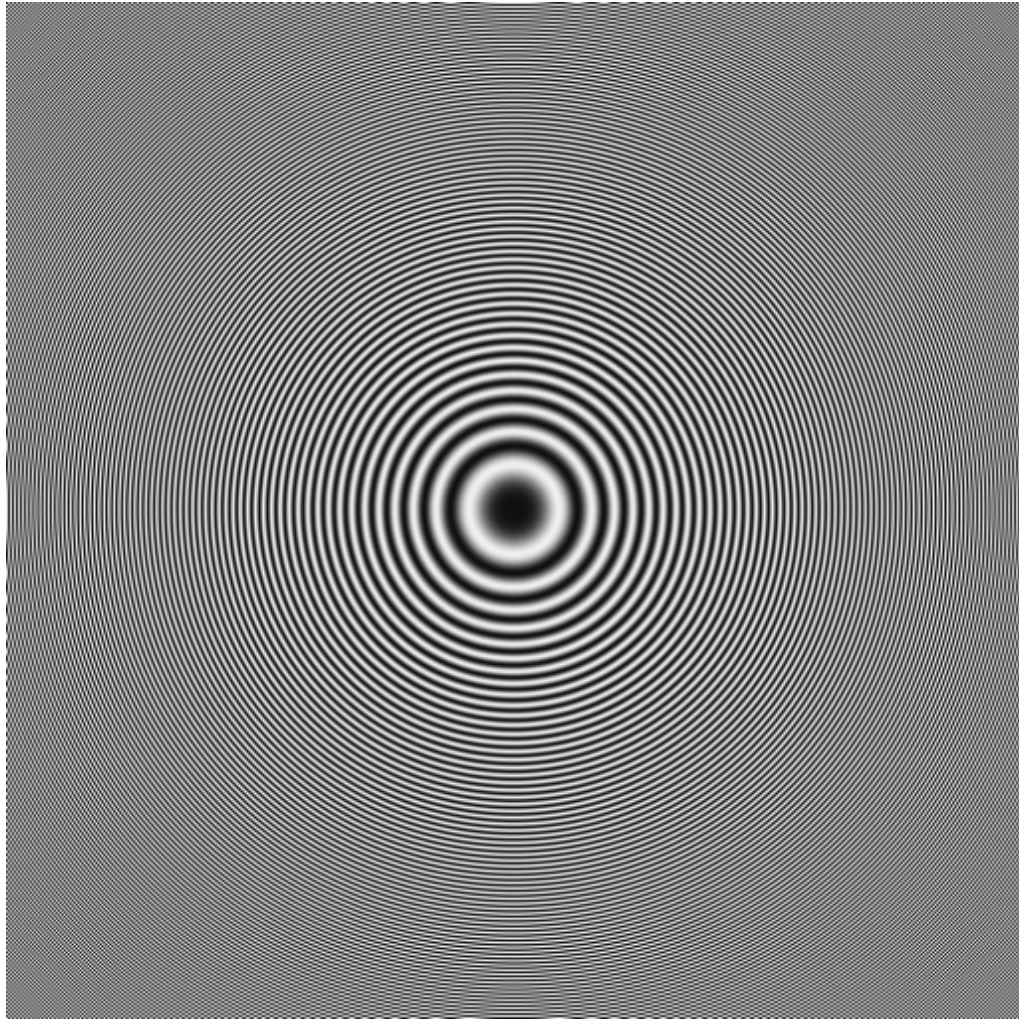

Original *Zoneplate* (512x512)

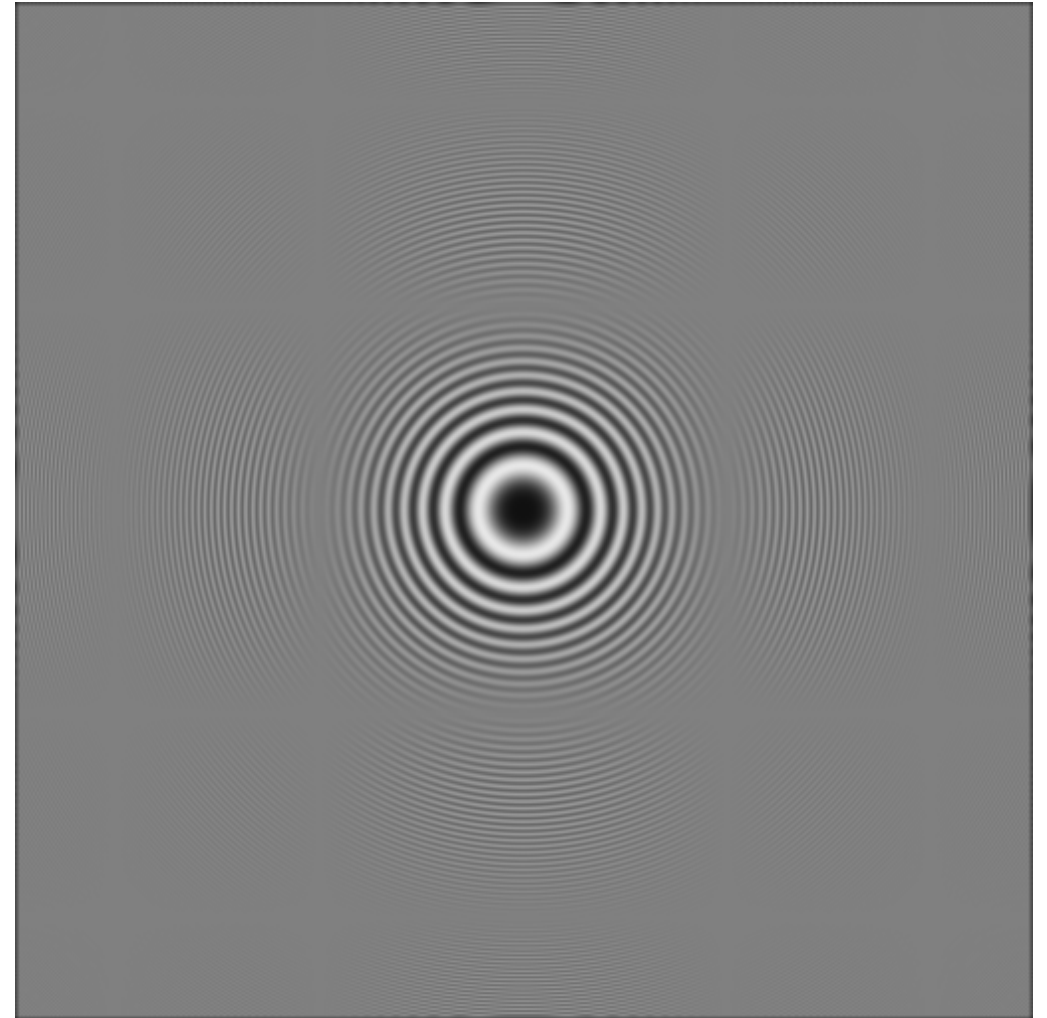

Lowpass filtered with 5x5 box filter

Zoneplate demonstration: 1-d sampling of 2-d signals

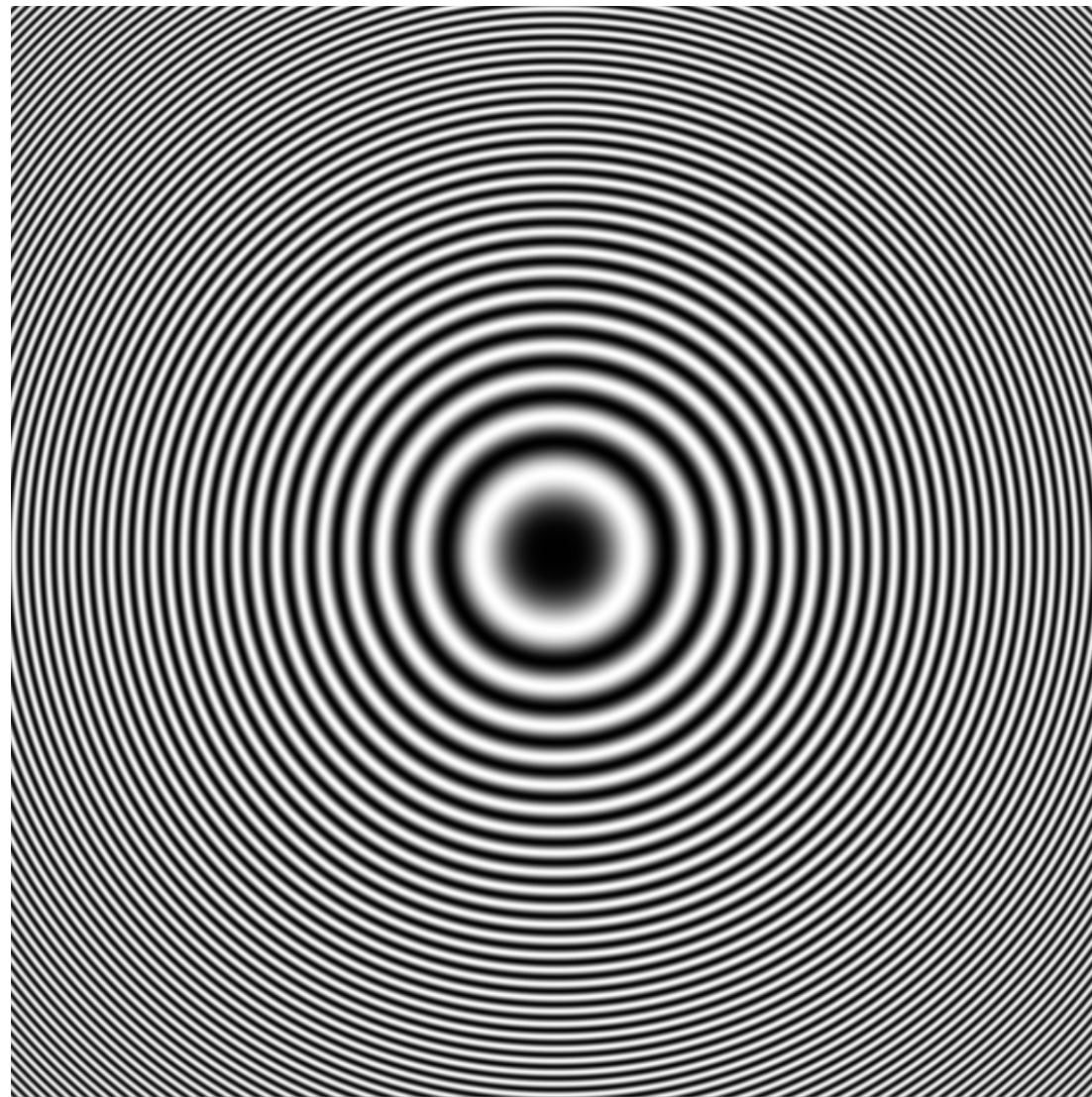

Zoneplate demonstration: 1-d sampling of 2-d signals

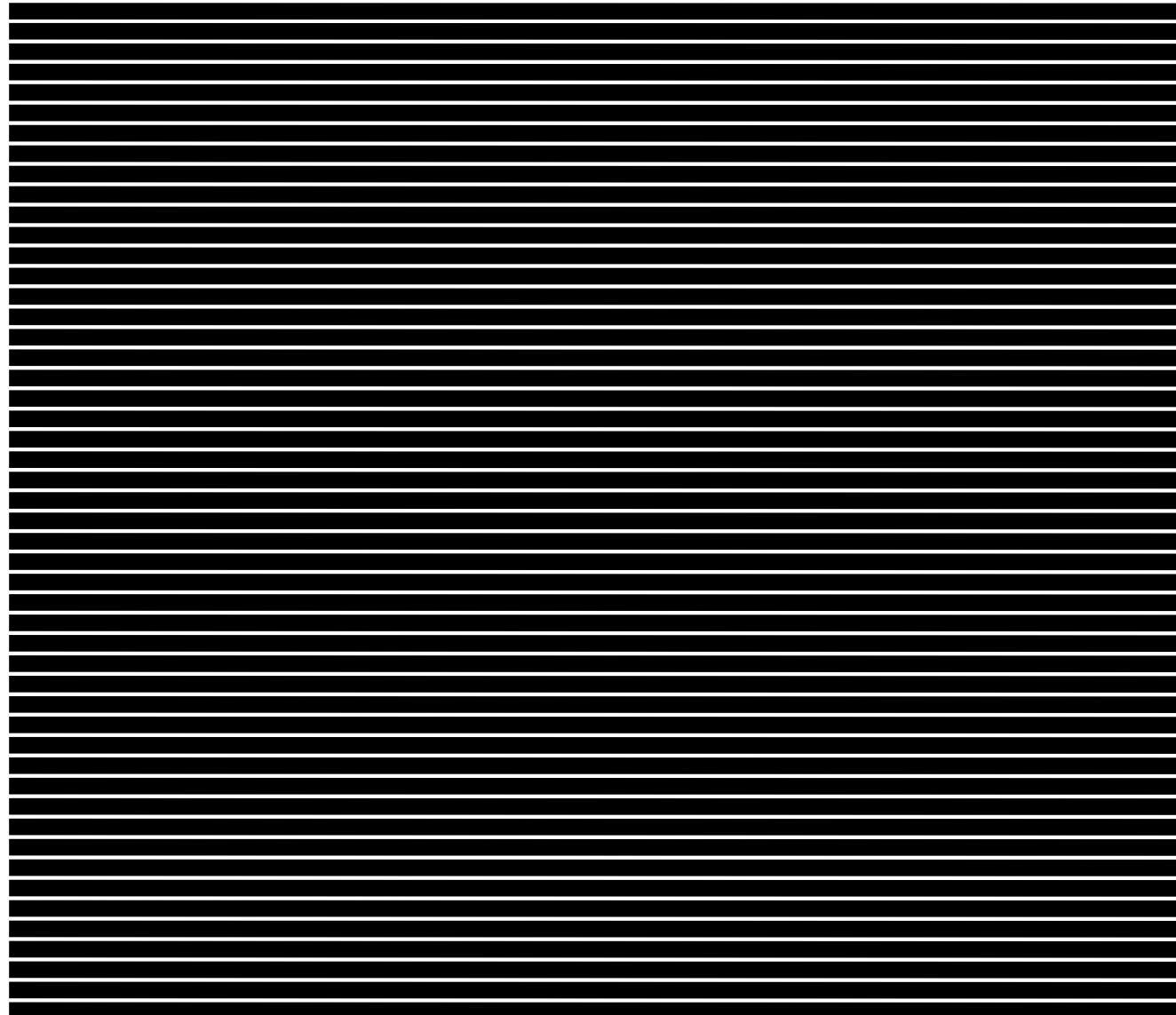

Zoneplate demonstration: 1-d sampling of 2-d signals

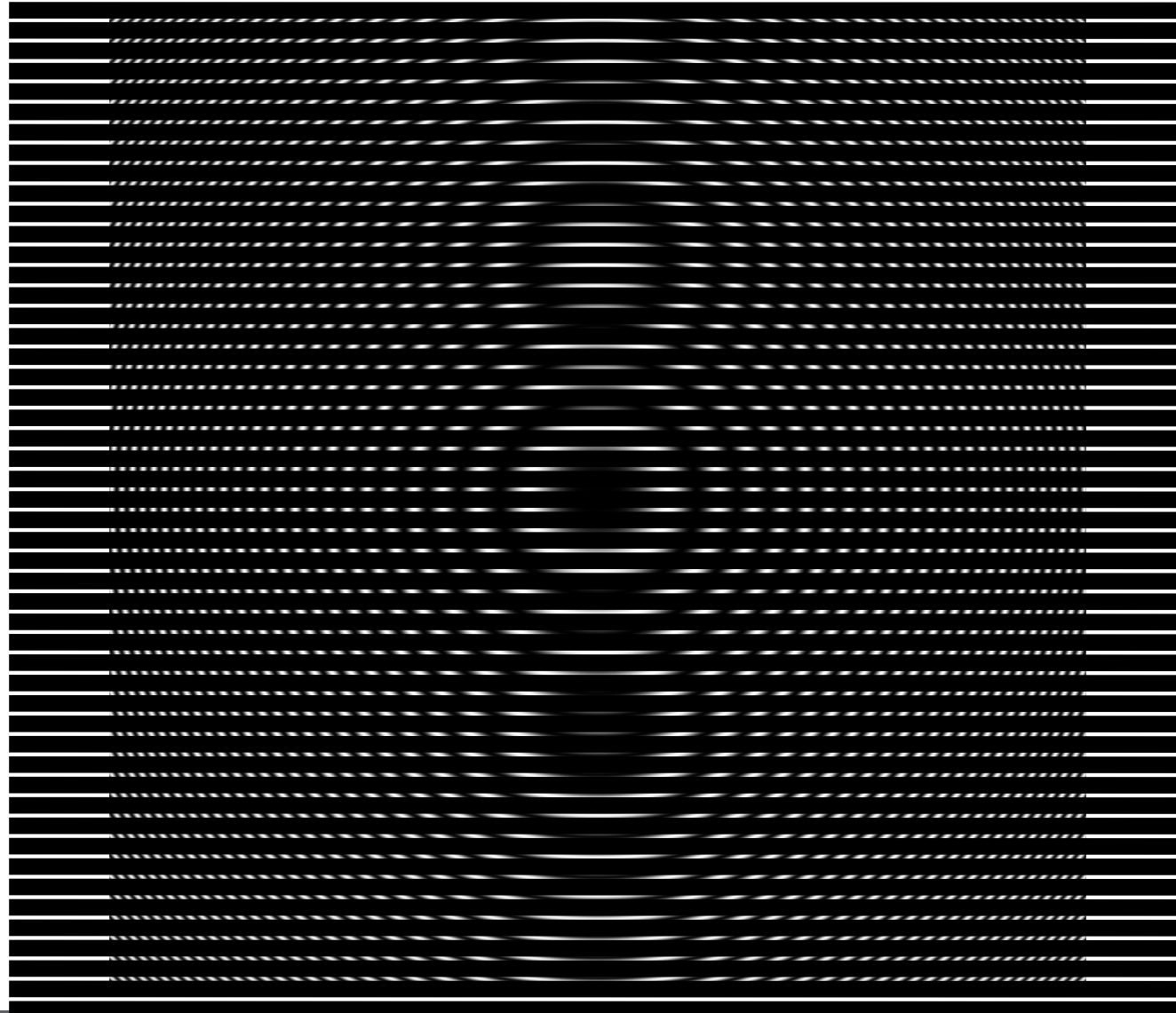

Zoneplate demonstration: 1-d sampling of 2-d signals

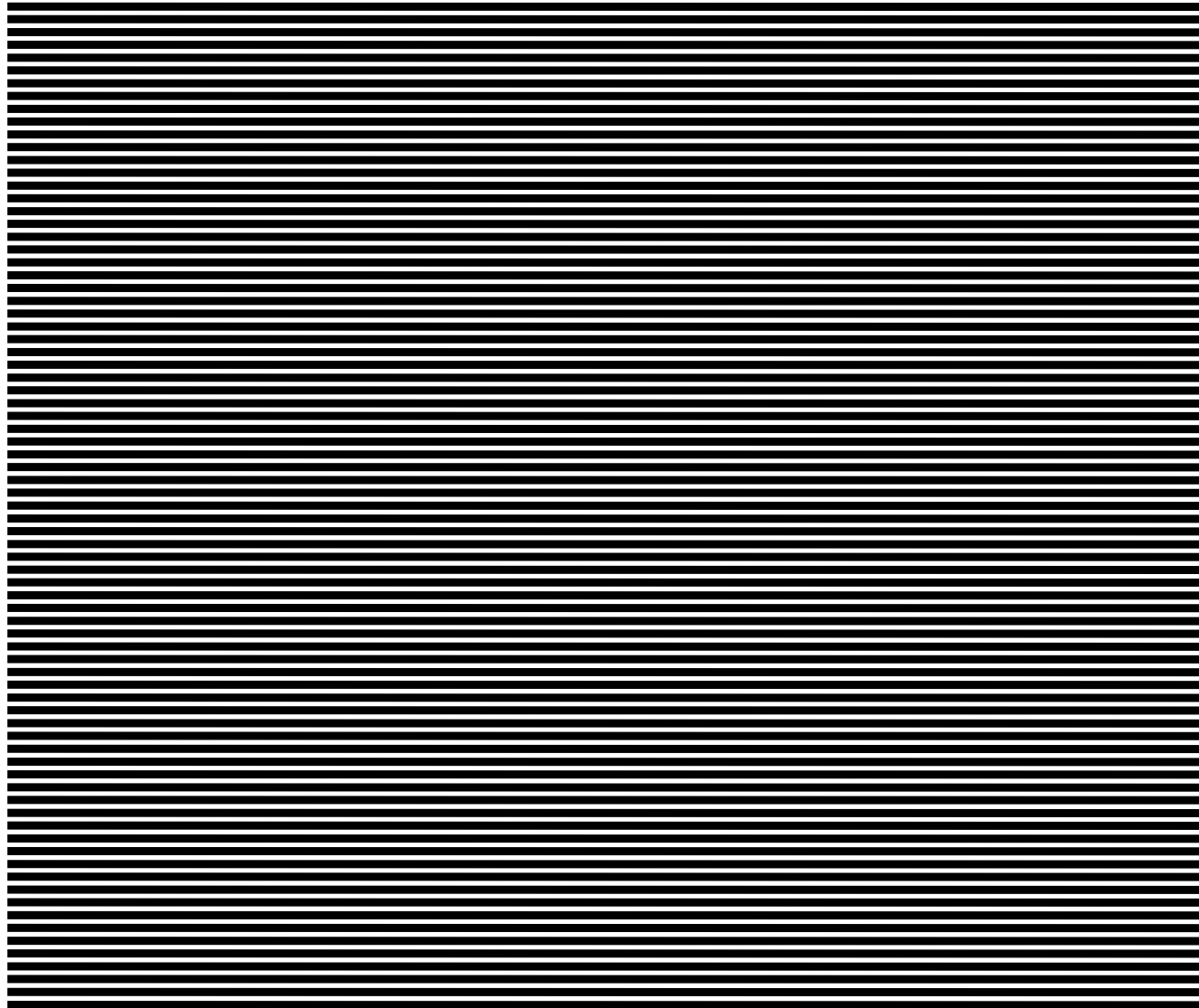

Zoneplate demonstration: 1-d sampling of 2-d signals

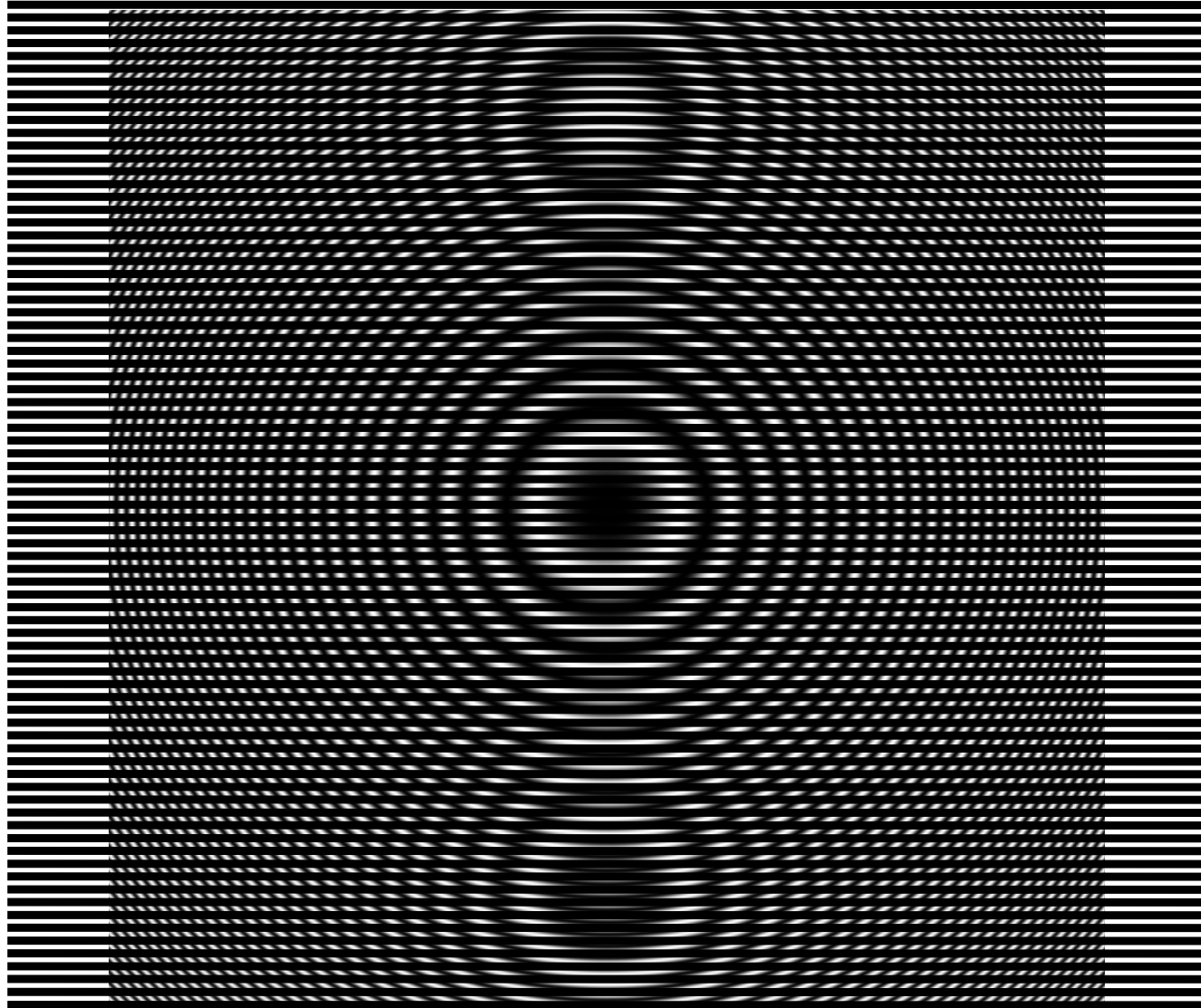

Zoneplate demonstration: 1-d sampling of 2-d signals

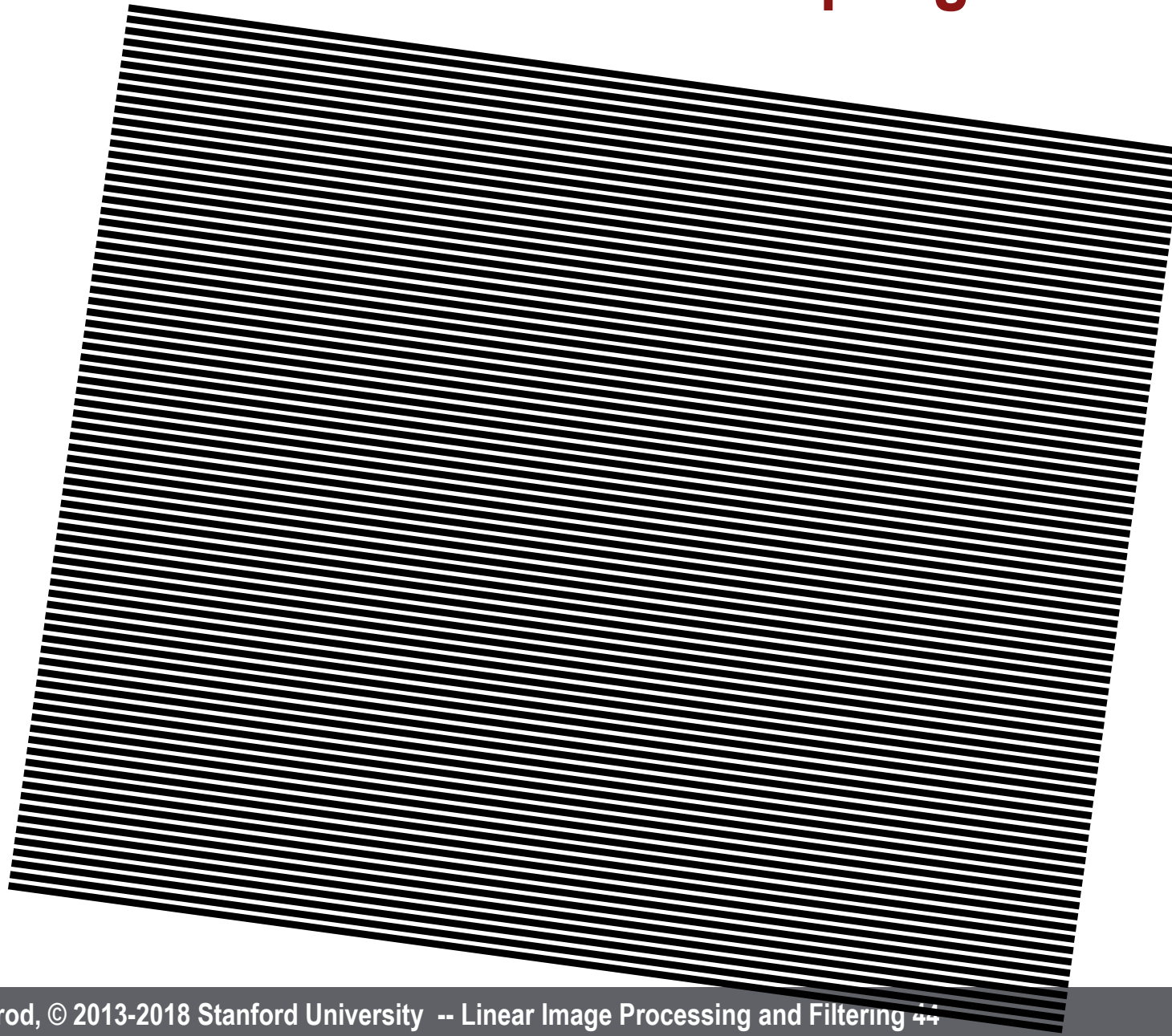

Zoneplate demonstration: 1-d sampling of 2-d signals

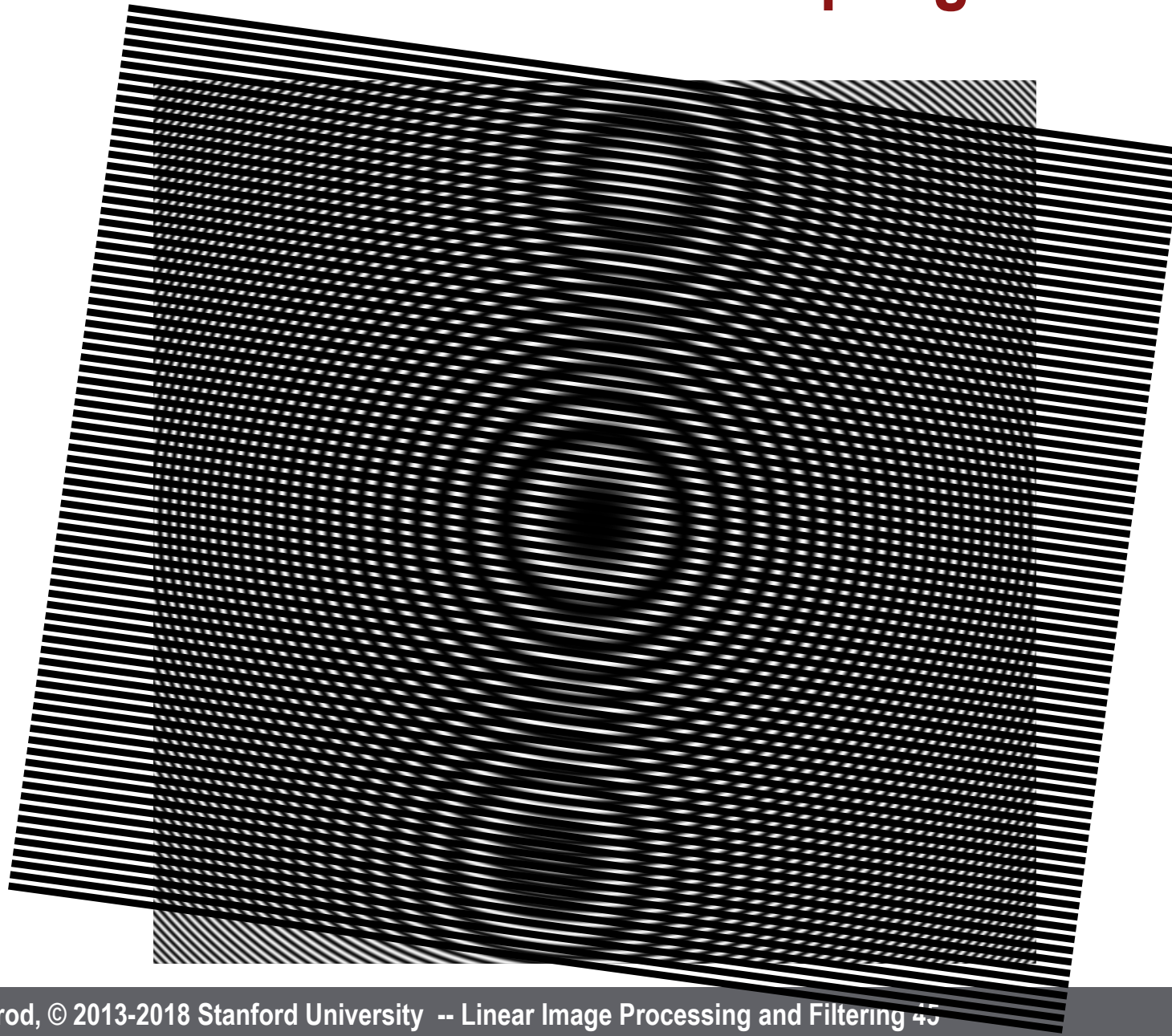

Horizontal/vertical 2:1 subsampling without prefiltering

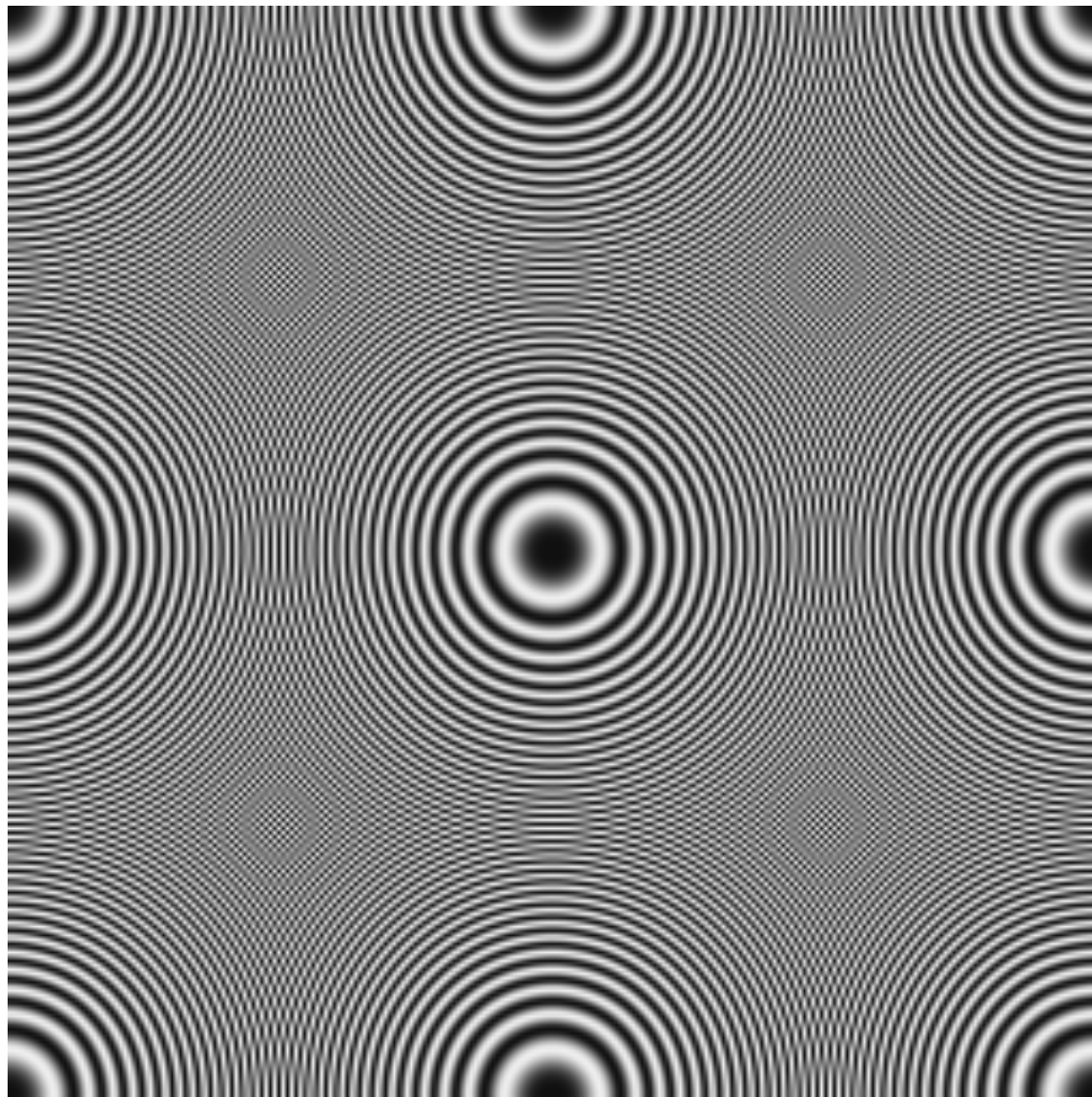

Horizontal/vertical 2:1 subsampling with prefiltering

2d impulse response

$$\begin{pmatrix} \frac{1}{16} & \frac{1}{8} & \frac{1}{16} \\ \frac{1}{8} & \frac{1}{4} & \frac{1}{8} \\ \frac{1}{16} & \frac{1}{8} & \frac{1}{16} \end{pmatrix}$$

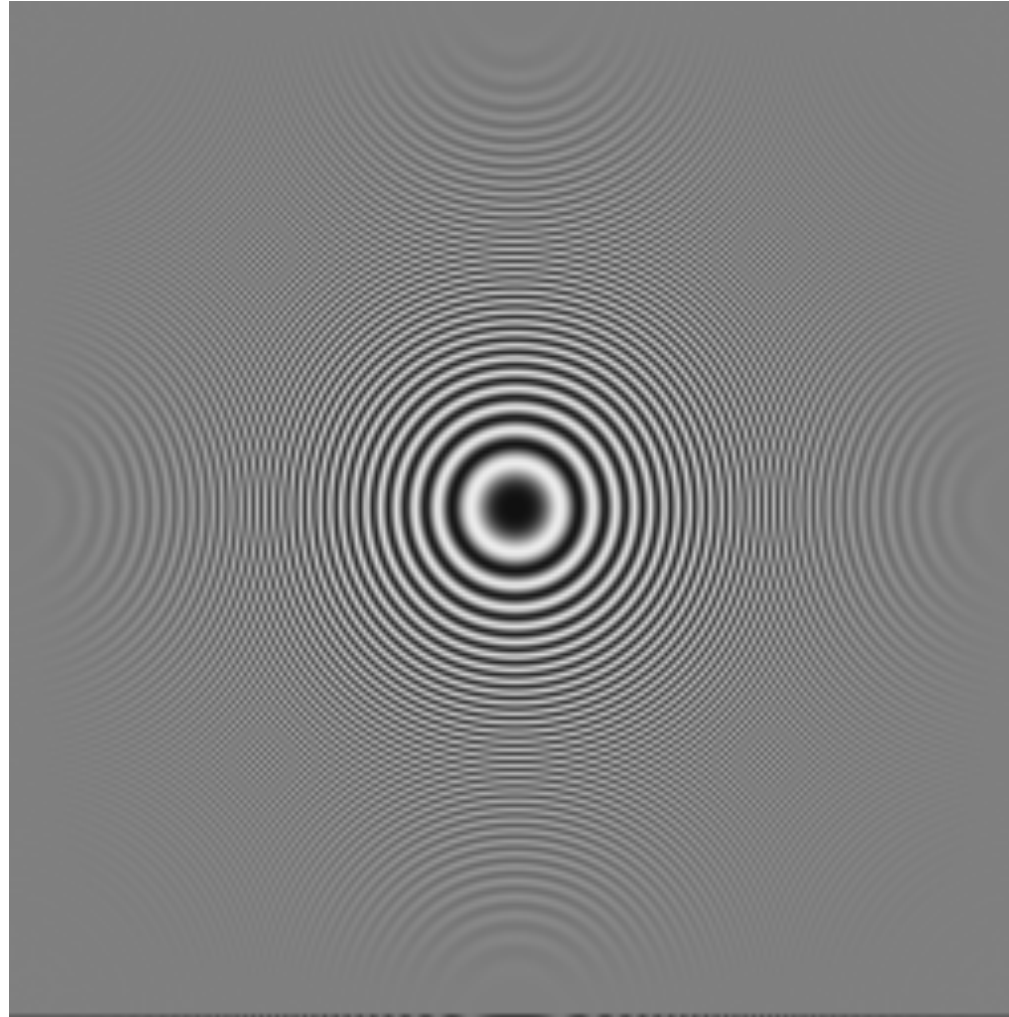

Frequency response

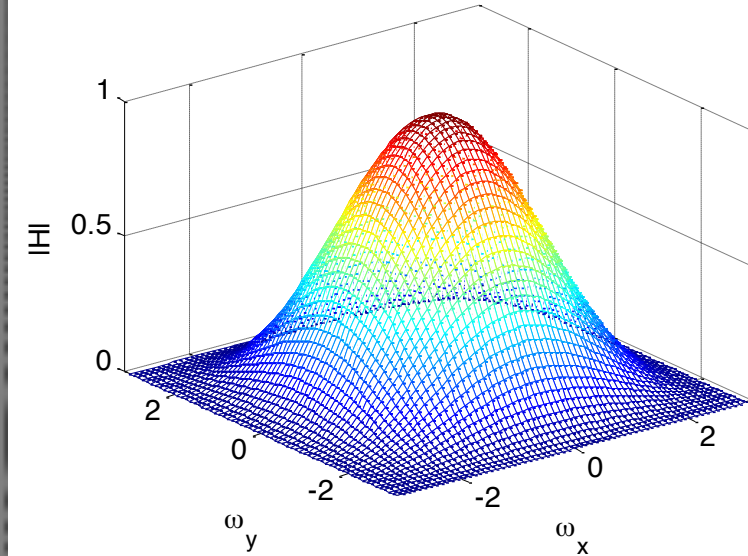
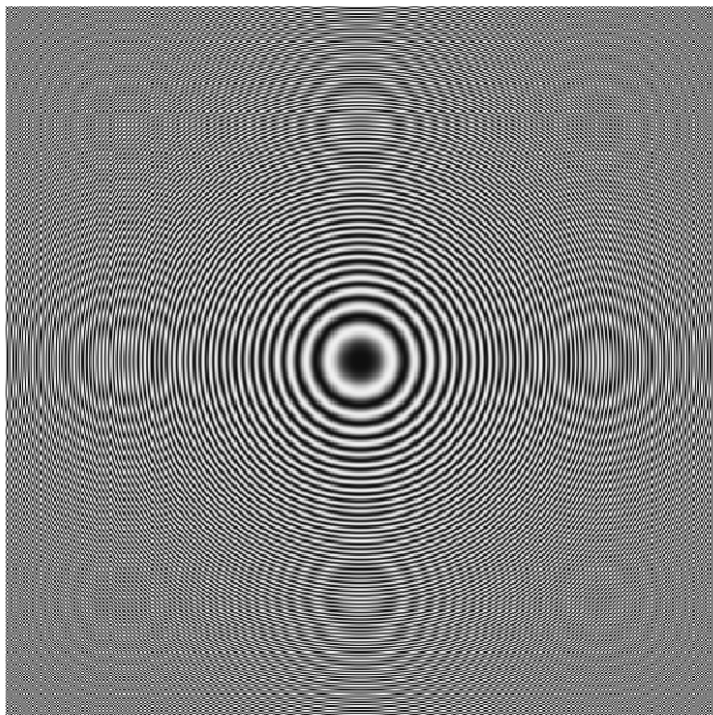
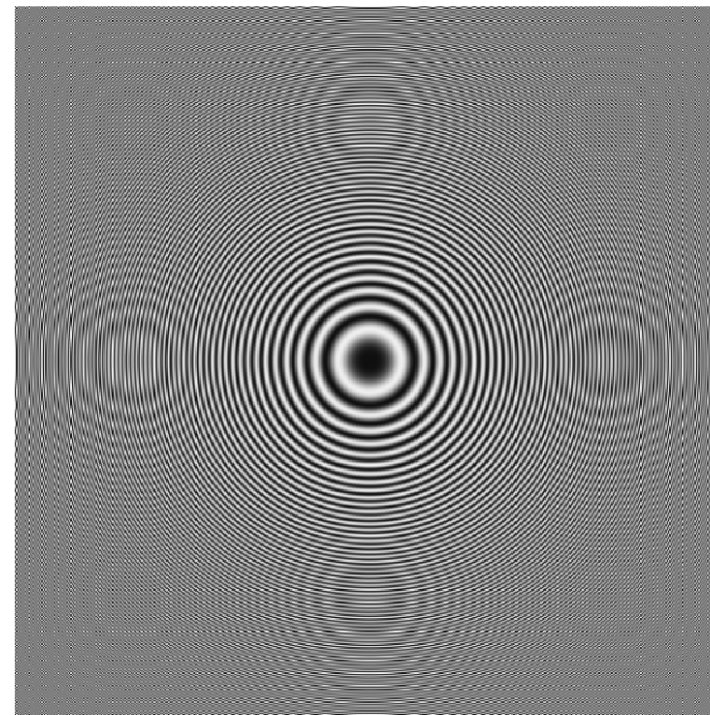

Image magnification (10%)



Nearest neighbor interpolation



Bilinear interpolation

Optical anti-aliasing filter removal

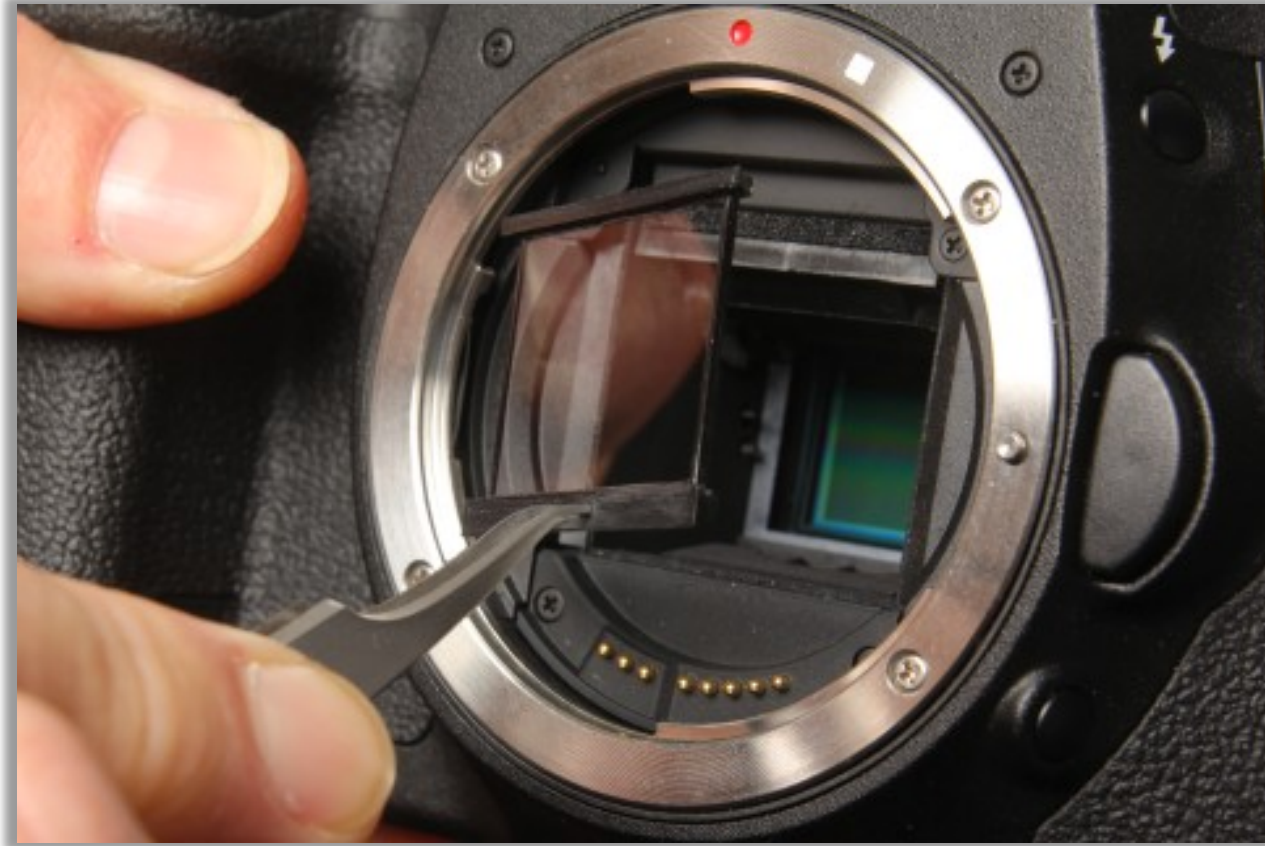

<http://www.mosaicengineering.com/products/vaf/60d/remove.html>

Optical anti-aliasing filter removal



without anti-aliasing



with anti-aliasing

Temporal aliasing (“wagon-wheel effect”)

Blurry images

Point source on focal plane maps to point

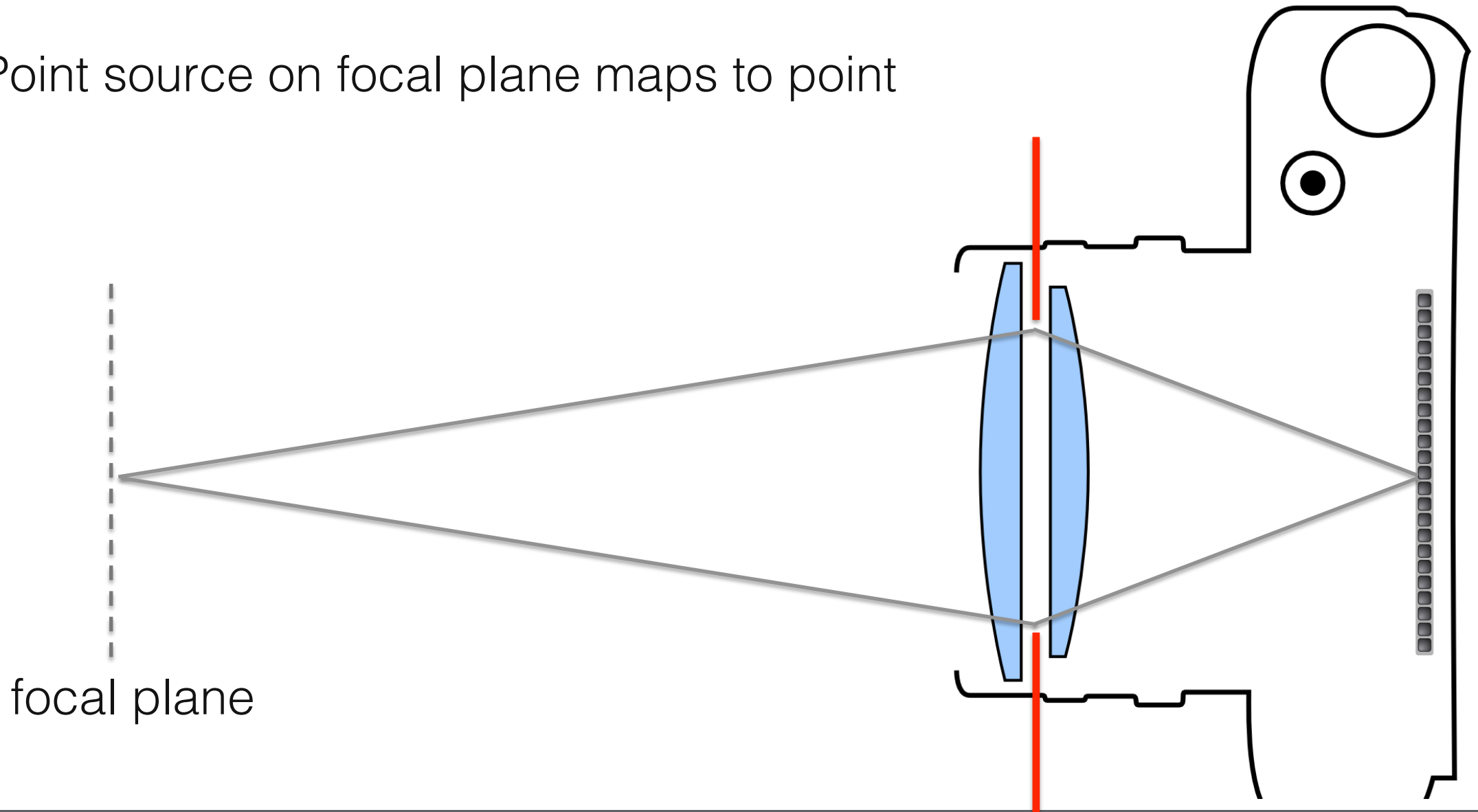

Blurry images

Away from focal plane: out-of-focus blur

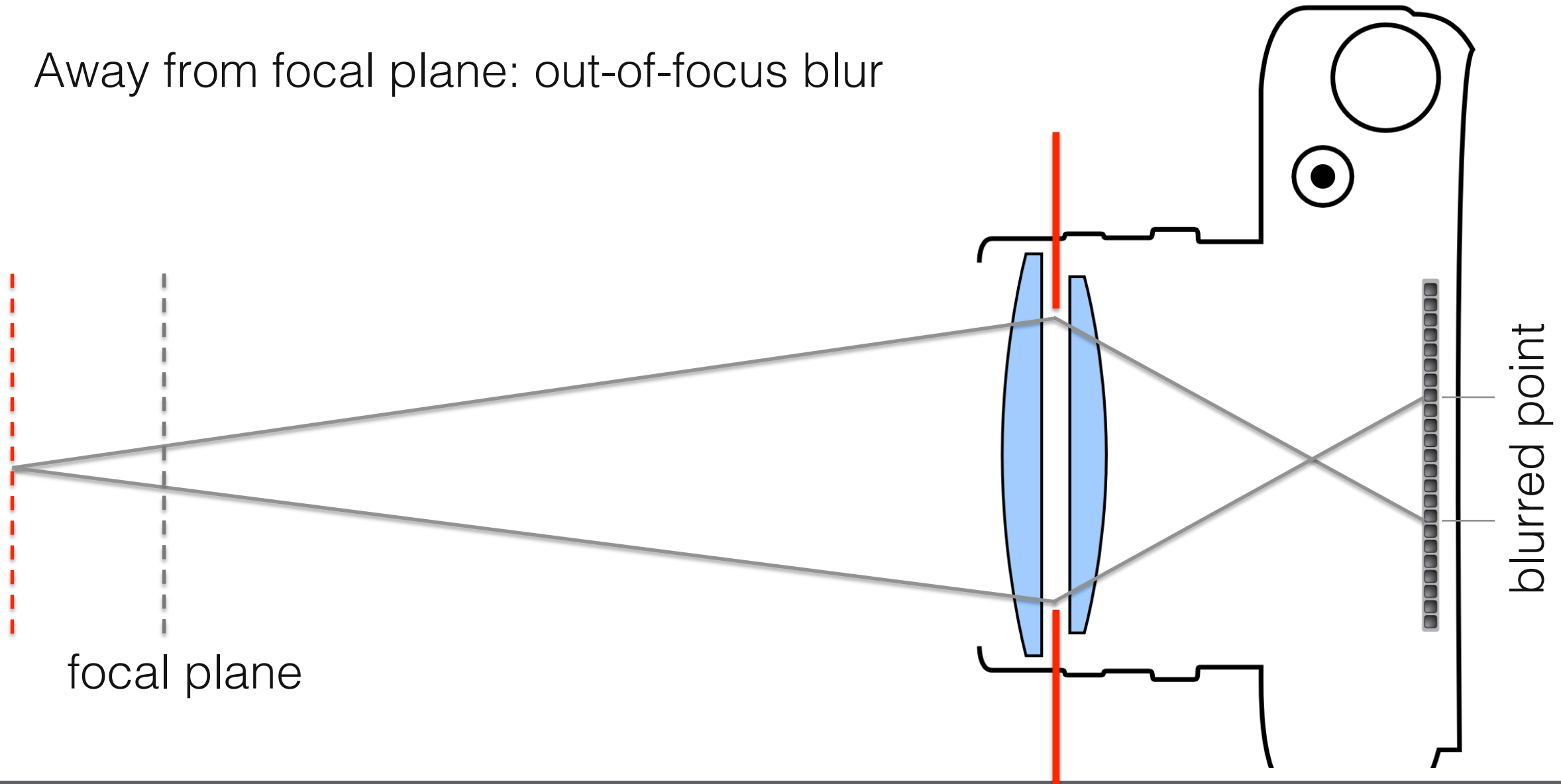

Blurry images

Linear + shift-invariant \rightarrow convolution!

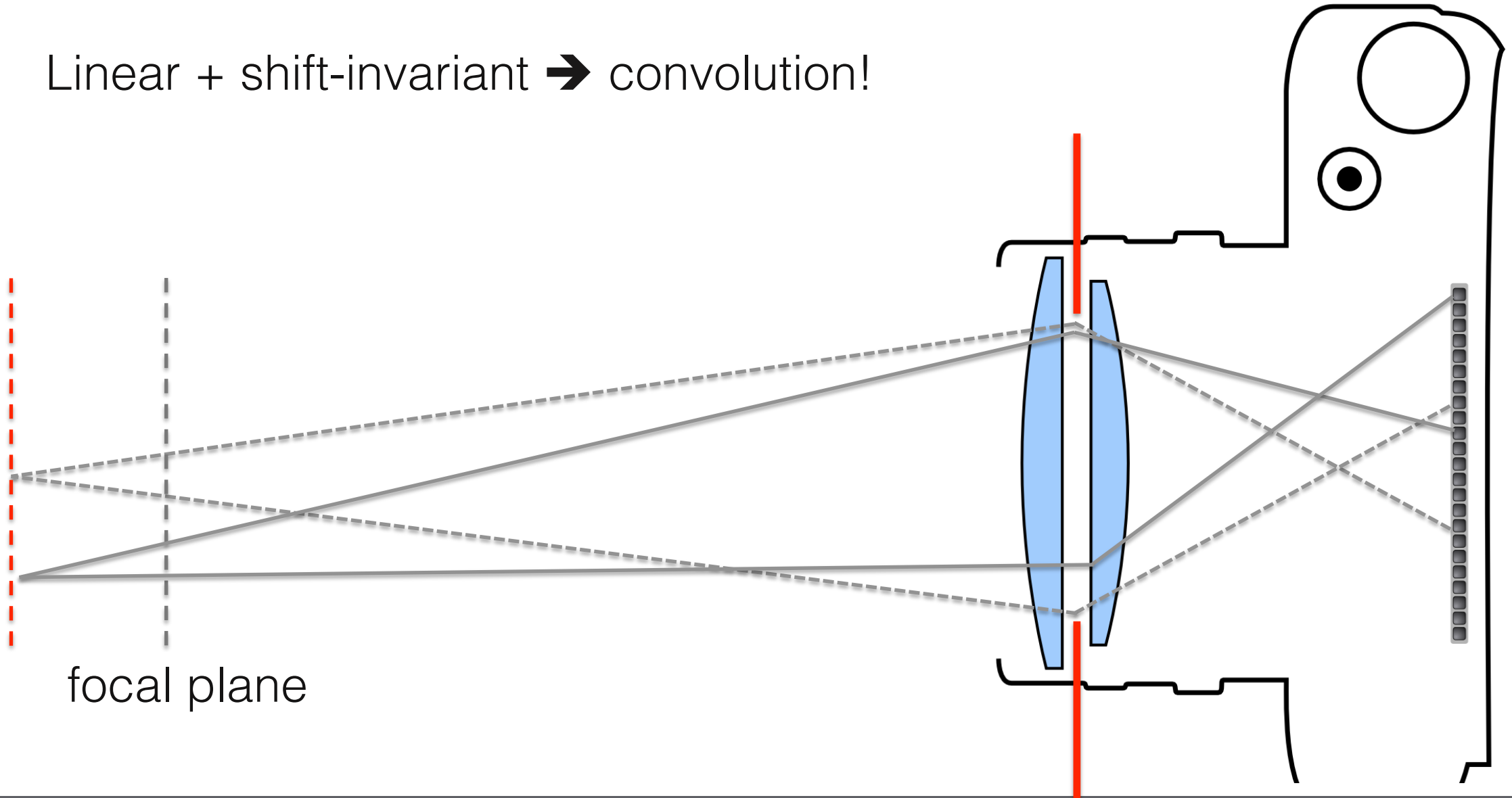

Blurry images

Motion blur: convolution as well.

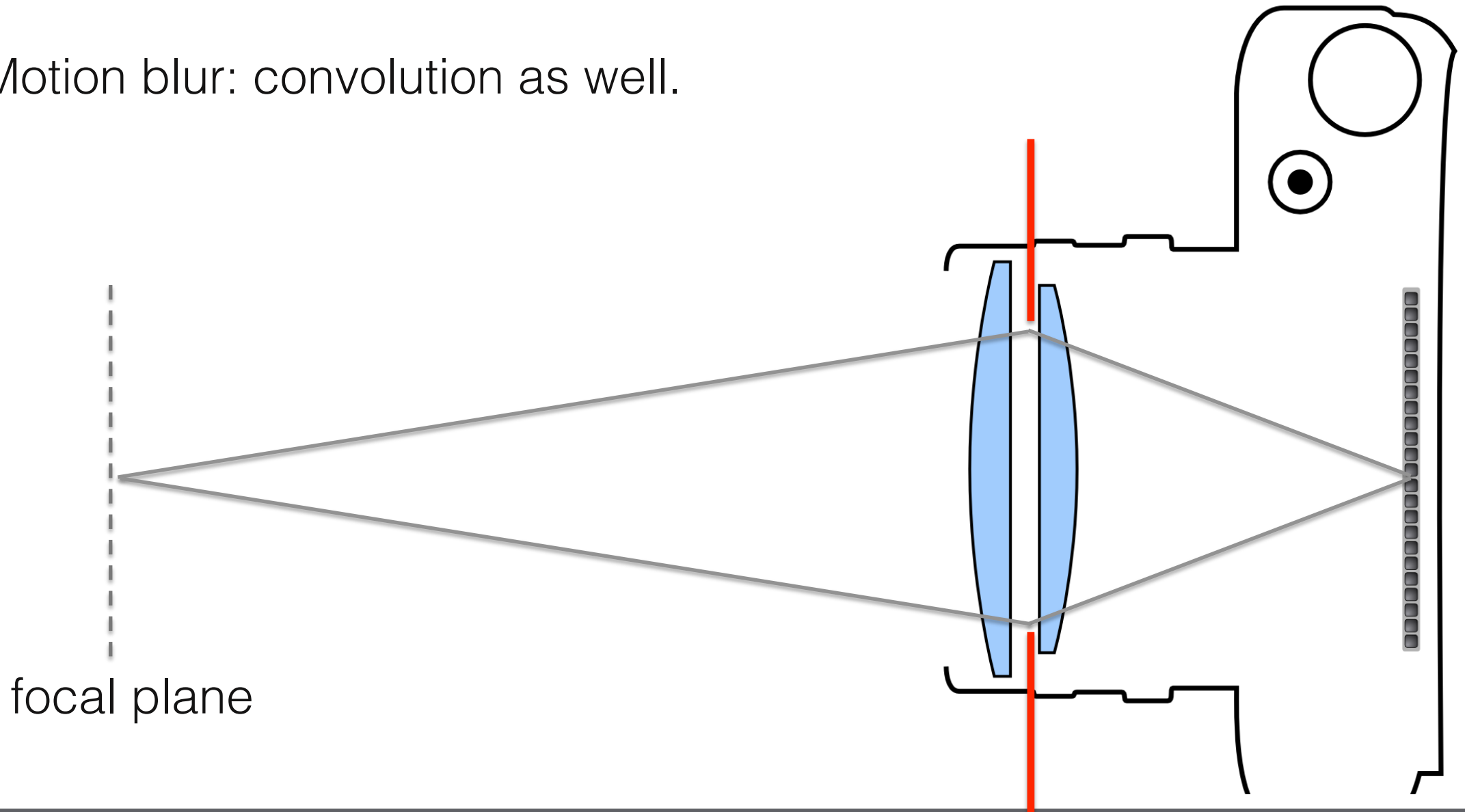
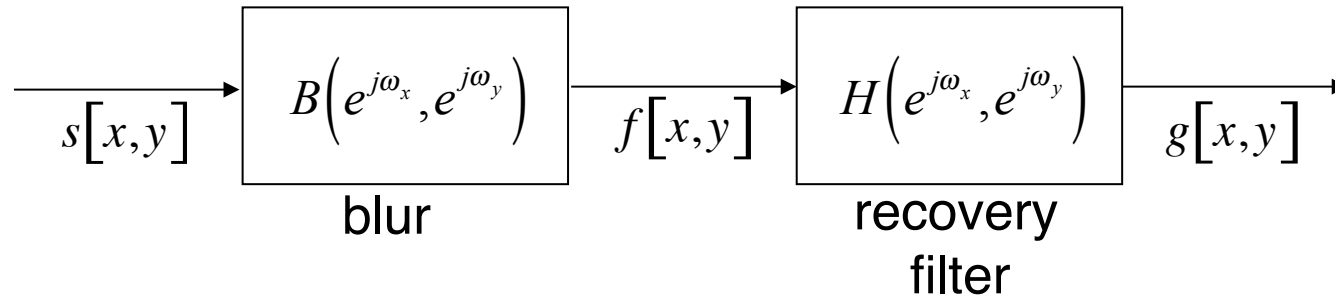

Image deconvolution

- Given an image $f[x,y]$ that is a blurred version of original image $s[x,y]$, recover the original image.
- Assume linear shift-invariant blur, transfer function $B(e^{j\omega_x}, e^{j\omega_y})$



- Naive solution: inverse filter

$$H(e^{j\omega_x}, e^{j\omega_y}) = \frac{1}{B(e^{j\omega_x}, e^{j\omega_y})}$$

- Problem: $B(e^{j\omega_x}, e^{j\omega_y})$ might be zero, noise amplification

Naïve deconvolution

Original

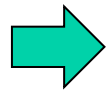

Blurred w/ $B(e^{j\omega_x}, e^{j\omega_y})$

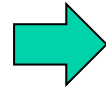

Deblurred w/ $B^{-1}(e^{j\omega_x}, e^{j\omega_y})$



+ white noise  $rms = 2.5$

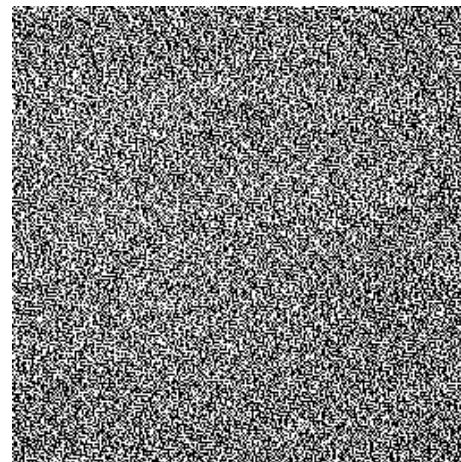
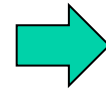

Wiener filtering

- Model

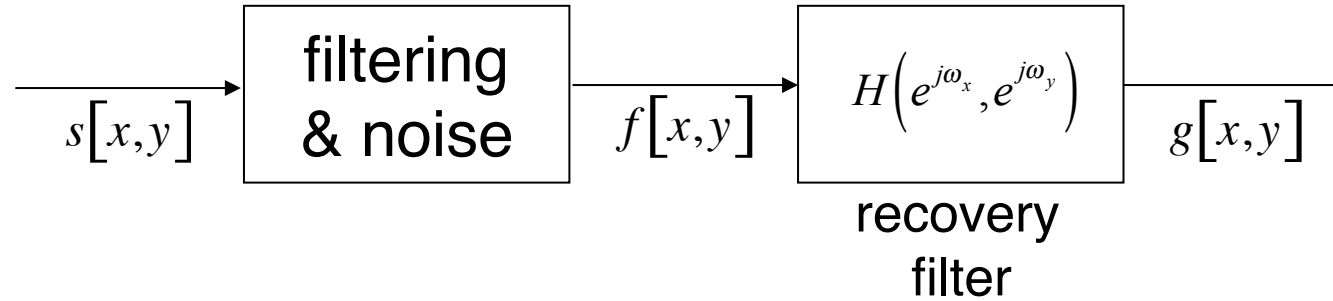

- Minimize mean squared estimation error

$$E\{e^2[x, y]\} = E\{(g[x, y] - s[x, y])^2\} \xrightarrow{H(e^{j\omega_x}, e^{j\omega_y})} \min.$$

- Power spectral density of estimation error

$$\begin{aligned}\Phi_{ee}(e^{j\omega_x}, e^{j\omega_y}) &= \Phi_{gg}(e^{j\omega_x}, e^{j\omega_y}) - \Phi_{gs}(e^{j\omega_x}, e^{j\omega_y}) - \Phi_{sg}(e^{j\omega_x}, e^{j\omega_y}) + \Phi_{ss}(e^{j\omega_x}, e^{j\omega_y}) \\ &= \Phi_{ff}(e^{j\omega_x}, e^{j\omega_y}) H(e^{j\omega_x}, e^{j\omega_y}) H^*(e^{j\omega_x}, e^{j\omega_y}) - \Phi_{fs}(e^{j\omega_x}, e^{j\omega_y}) H(e^{j\omega_x}, e^{j\omega_y}) \\ &\quad - \Phi_{sf}(e^{j\omega_x}, e^{j\omega_y}) H^*(e^{j\omega_x}, e^{j\omega_y}) + \Phi_{ss}(e^{j\omega_x}, e^{j\omega_y})\end{aligned}$$

Review: Power spectrum and cross spectrum

- 2-d discrete-space cross correlation function for ergodic, stationary signals

$$\varphi_{fg}[m,n] = E \left\{ f[x+m, y+n] g^*[x, y] \right\}$$

- Special case: autocorrelation function

$$\varphi_{ff}[m,n] = E \left\{ f[x+m, y+n] f^*[x, y] \right\}$$

- Cross spectral density

$$\Phi_{fg}(e^{j\omega_x}, e^{j\omega_y}) = \sum_{m=-\infty}^{\infty} \sum_{n=-\infty}^{\infty} \varphi_{fg}[m,n] e^{-j\omega_x m - j\omega_y n}$$

- Power spectral density

$$\Phi_{ff}(e^{j\omega_x}, e^{j\omega_y}) = \sum_{m=-\infty}^{\infty} \sum_{n=-\infty}^{\infty} \varphi_{ff}[m,n] e^{-j\omega_x m - j\omega_y n}$$

Wiener filtering (cont.)

- Power spectrum Φ_{ee} is minimized separately at each frequency ω_x, ω_y if

$$H(e^{j\omega_x}, e^{j\omega_y}) = \frac{\Phi_{fs}^*(e^{j\omega_x}, e^{j\omega_y})}{\Phi_{ff}(e^{j\omega_x}, e^{j\omega_y})} = \frac{\Phi_{sf}(e^{j\omega_x}, e^{j\omega_y})}{\Phi_{ff}(e^{j\omega_x}, e^{j\omega_y})}$$

- Can be shown to be global minimum by considering filter

$$H(e^{j\omega_x}, e^{j\omega_y}) = \frac{\Phi_{fs}^*(e^{j\omega_x}, e^{j\omega_y})}{\Phi_{ff}(e^{j\omega_x}, e^{j\omega_y})} + \Delta H(e^{j\omega_x}, e^{j\omega_y})$$

Wiener filter for linear distortion and additive noise

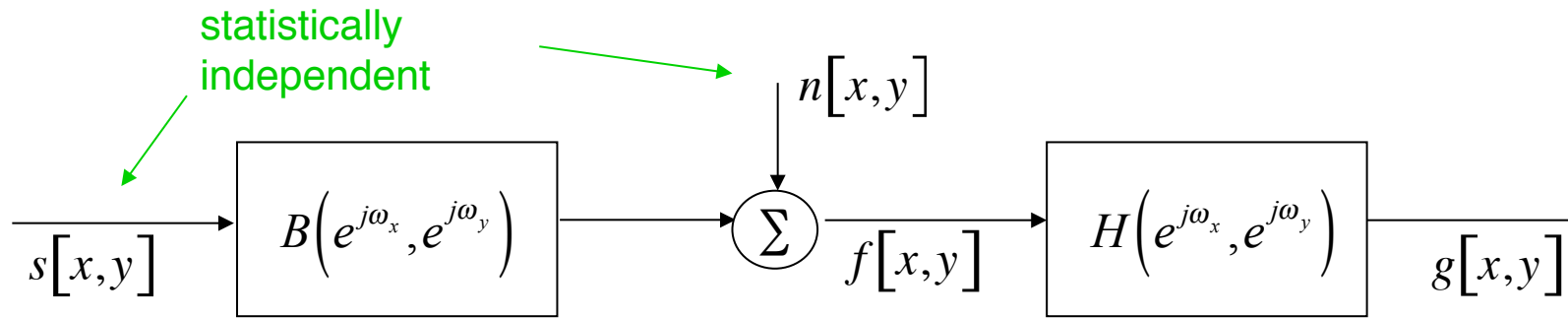

$$\Phi_{sf}(e^{j\omega_x}, e^{j\omega_y}) = \Phi_{ss}(e^{j\omega_x}, e^{j\omega_y}) B^*(e^{j\omega_x}, e^{j\omega_y})$$

$$\Phi_{ff}(e^{j\omega_x}, e^{j\omega_y}) = \Phi_{ss}(e^{j\omega_x}, e^{j\omega_y}) \left| B(e^{j\omega_x}, e^{j\omega_y}) \right|^2 + \Phi_{nn}(e^{j\omega_x}, e^{j\omega_y})$$

$$H(e^{j\omega_x}, e^{j\omega_y}) = \frac{\Phi_{ss}(e^{j\omega_x}, e^{j\omega_y}) B^*(e^{j\omega_x}, e^{j\omega_y})}{\Phi_{ss}(e^{j\omega_x}, e^{j\omega_y}) \left| B(e^{j\omega_x}, e^{j\omega_y}) \right|^2 + \Phi_{nn}(e^{j\omega_x}, e^{j\omega_y})}$$

Wiener filter for linear distortion and additive noise

Blurred w/ $B(e^{j\omega_x}, e^{j\omega_y})$
Add. white noise, $rms = 2.5$



Deblurred
 $B^{-1}(e^{j\omega_x}, e^{j\omega_y})$

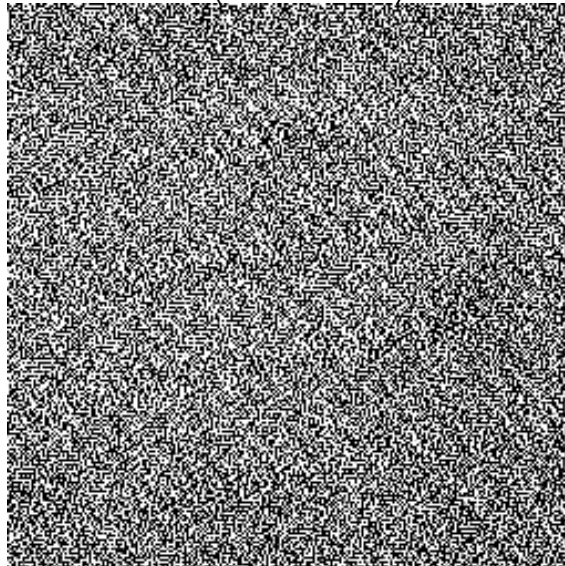

Wiener Filter

$$\frac{\Phi_{ss}(e^{j\omega_x}, e^{j\omega_y})B^*(e^{j\omega_x}, e^{j\omega_y})}{\Phi_{ss}(e^{j\omega_x}, e^{j\omega_y})|B(e^{j\omega_x}, e^{j\omega_y})|^2 + \Phi_{nn}(e^{j\omega_x}, e^{j\omega_y})}$$

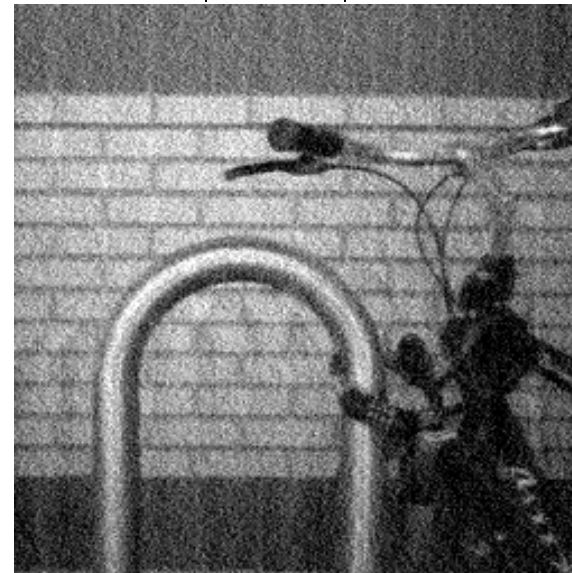

Wiener filter for additive noise

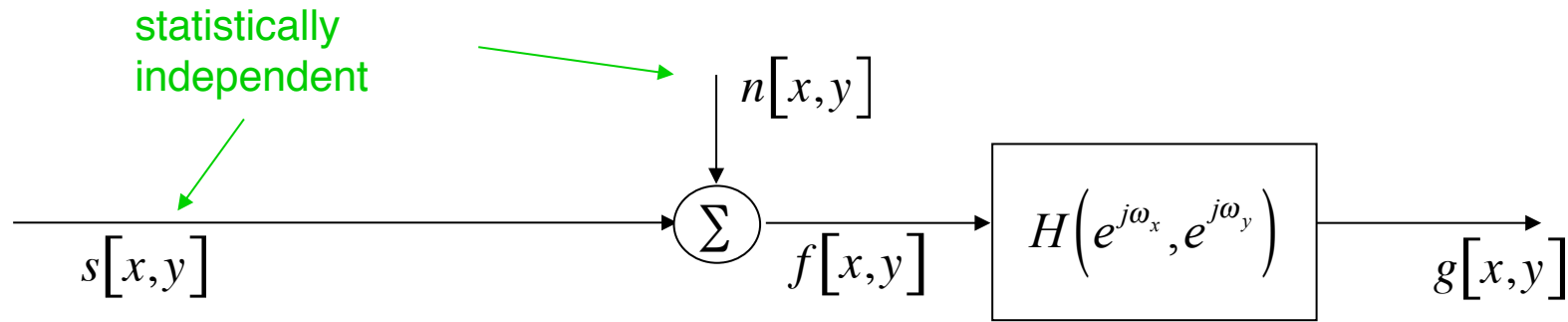

$$H(e^{j\omega_x}, e^{j\omega_y}) = \frac{\Phi_{ss}(e^{j\omega_x}, e^{j\omega_y})}{\Phi_{ss}(e^{j\omega_x}, e^{j\omega_y}) + \Phi_{nn}(e^{j\omega_x}, e^{j\omega_y})}$$

Wiener filter for additive noise

Original



Additive
white noise

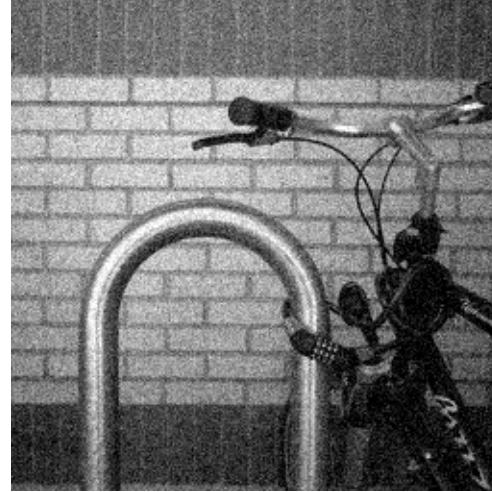

$$rms = 17.7$$

Noise reduction
by Wiener filtering

$$rms = 8.8$$



Nonlinear noise reduction/sharpening

- Noise reduction: smooth the image, lowpass filtering
- Deblurring: sharpen edges, highpass filtering
- How can both be achieved simultaneously?
- Key insight: large amplitude of highpass filtered image indicates presence of edge

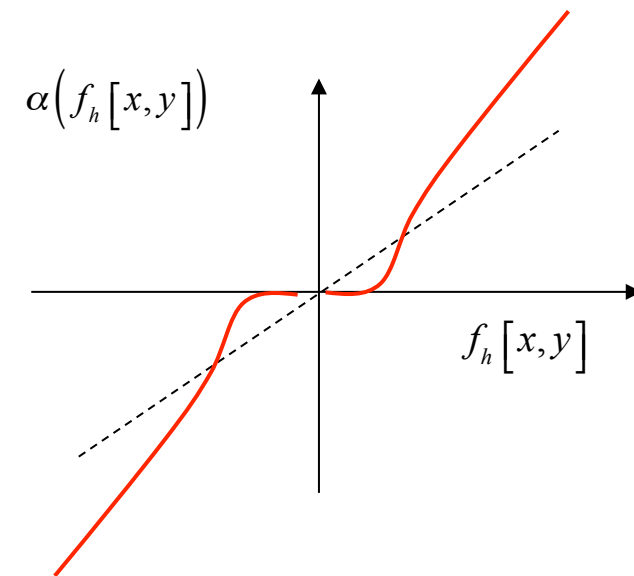
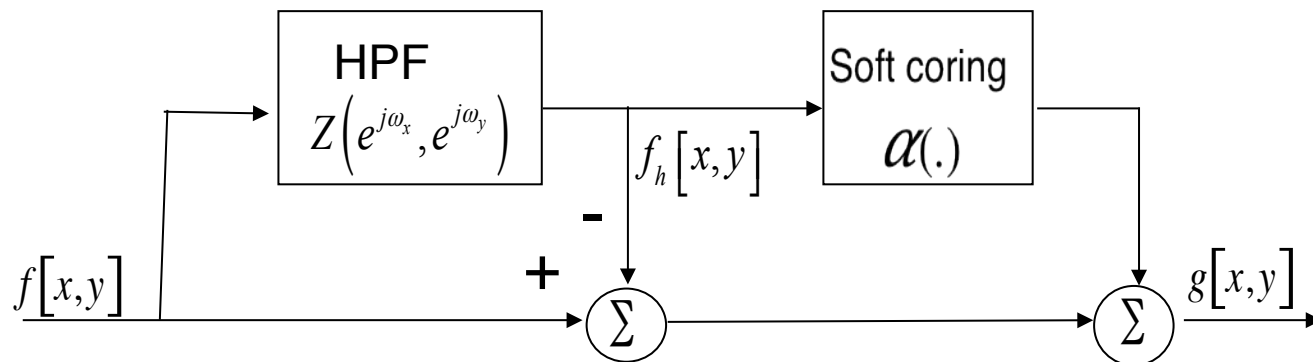

- Can be extended to multiple HPFs

Nonlinear noise reduction/sharpening (cont.)

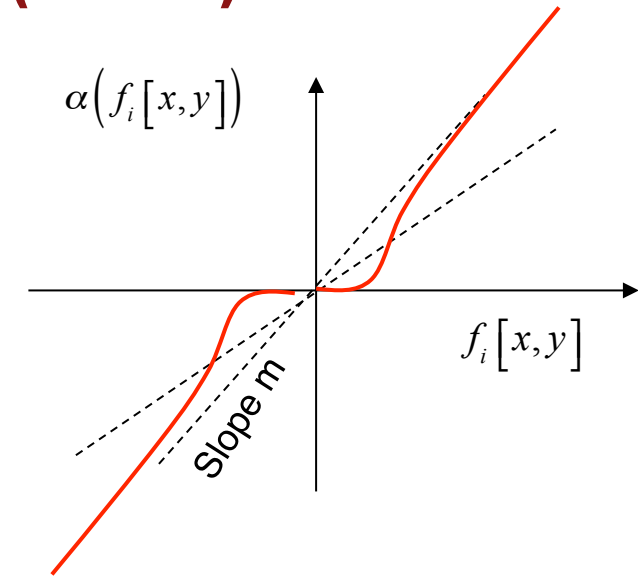
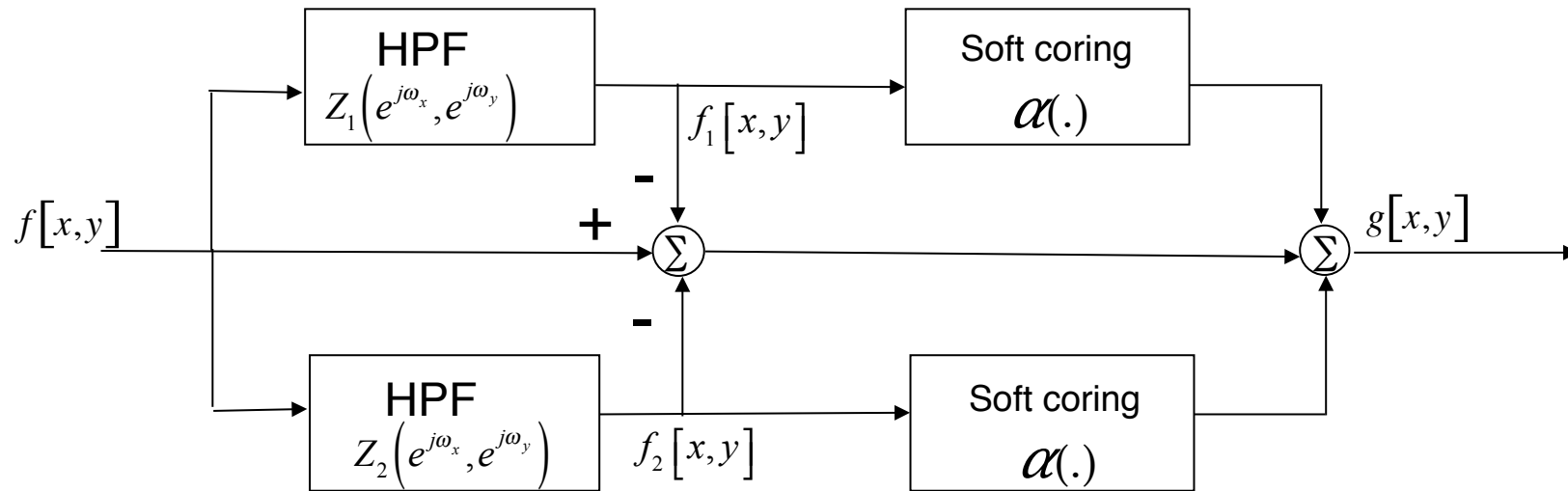

- Flat areas: $\alpha \approx 0 \rightarrow H(e^{j\omega_x}, e^{j\omega_y}) \approx 1 - Z_1(e^{j\omega_x}, e^{j\omega_y}) - Z_2(e^{j\omega_x}, e^{j\omega_y})$
- f_1 small; f_2 large: $H(e^{j\omega_x}, e^{j\omega_y}) \approx 1 - Z_1(e^{j\omega_x}, e^{j\omega_y}) + (m-1)Z_2(e^{j\omega_x}, e^{j\omega_y})$
- f_1 large; f_2 small: $H(e^{j\omega_x}, e^{j\omega_y}) \approx 1 + (m-1)Z_1(e^{j\omega_x}, e^{j\omega_y}) - Z_2(e^{j\omega_x}, e^{j\omega_y})$
- Both large: $H(e^{j\omega_x}, e^{j\omega_y}) \approx 1 + (m-1)[Z_1(e^{j\omega_x}, e^{j\omega_y}) + Z_2(e^{j\omega_x}, e^{j\omega_y})]$

Nonlinear noise reduction/sharpening example



blurred, noisy image

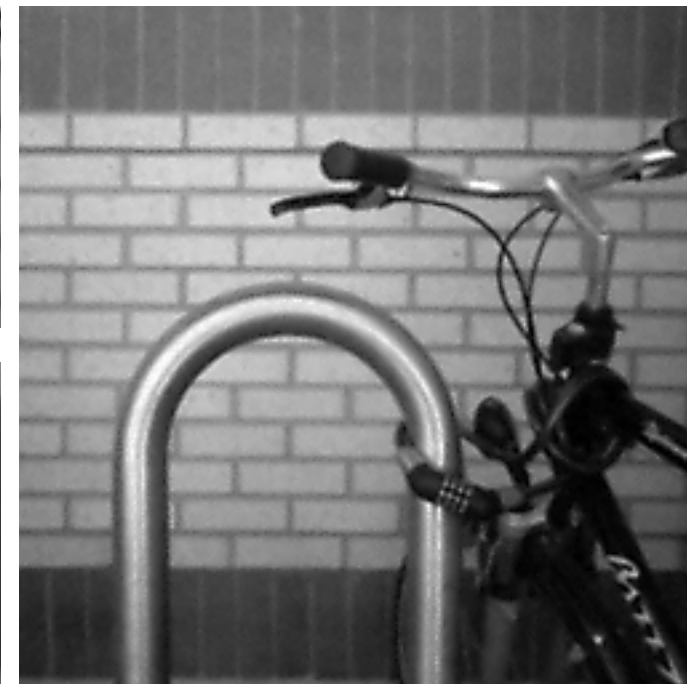
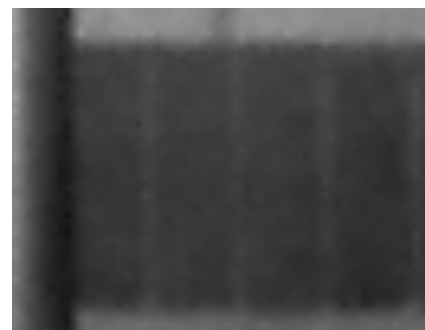
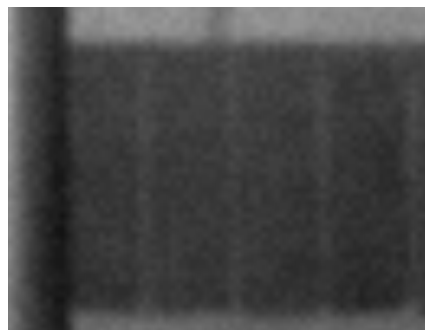
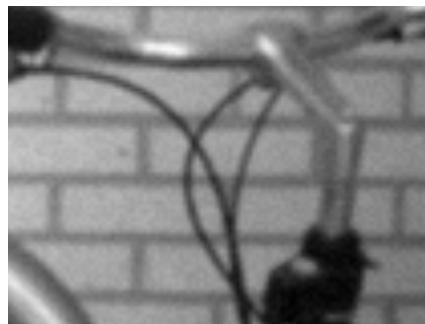

noise-reduced
and sharpened



Highpass filtered images

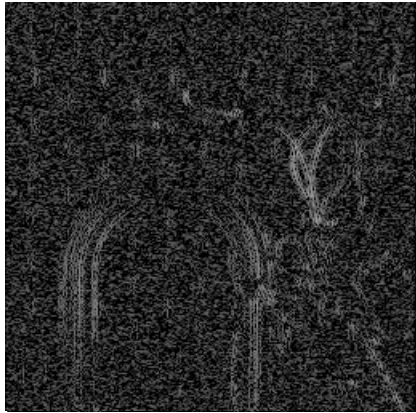

log magnitude of
image filtered with

$$\begin{pmatrix} 0 & 0 & 0 \\ -0.5 & [1] & -0.5 \\ 0 & 0 & 0 \end{pmatrix}$$

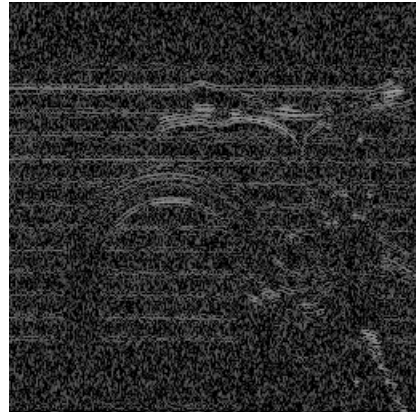

log magnitude of
image filtered with

$$\begin{pmatrix} 0 & -0.5 & 0 \\ 0 & [1] & 0 \\ 0 & -0.5 & 0 \end{pmatrix}$$

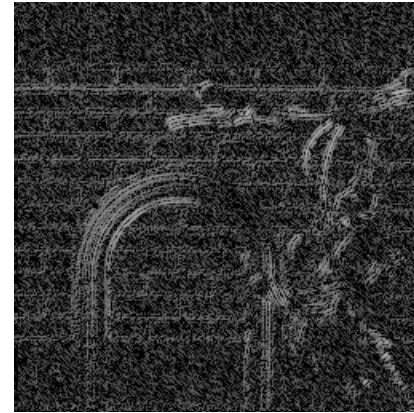

log magnitude of
image filtered with

$$\begin{pmatrix} -0.5 & 0 & 0 \\ 0 & [1] & 0 \\ 0 & 0 & -0.5 \end{pmatrix}$$

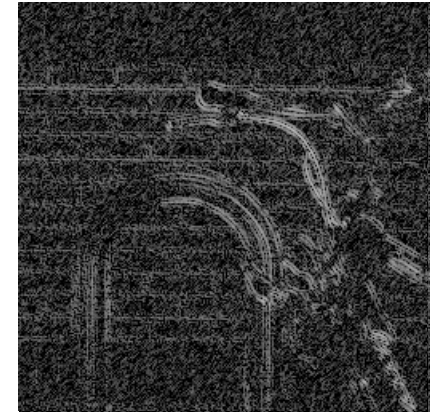

log magnitude of
image filtered with

$$\begin{pmatrix} 0 & 0 & -0.5 \\ 0 & [1] & 0 \\ -0.5 & 0 & 0 \end{pmatrix}$$



Soft coring function

$$\alpha(f_i[x,y]) = m \cdot f_i[x,y] \cdot \left(1 - e^{-\frac{|f_i[x,y]|^\gamma}{\tau}} \right)$$

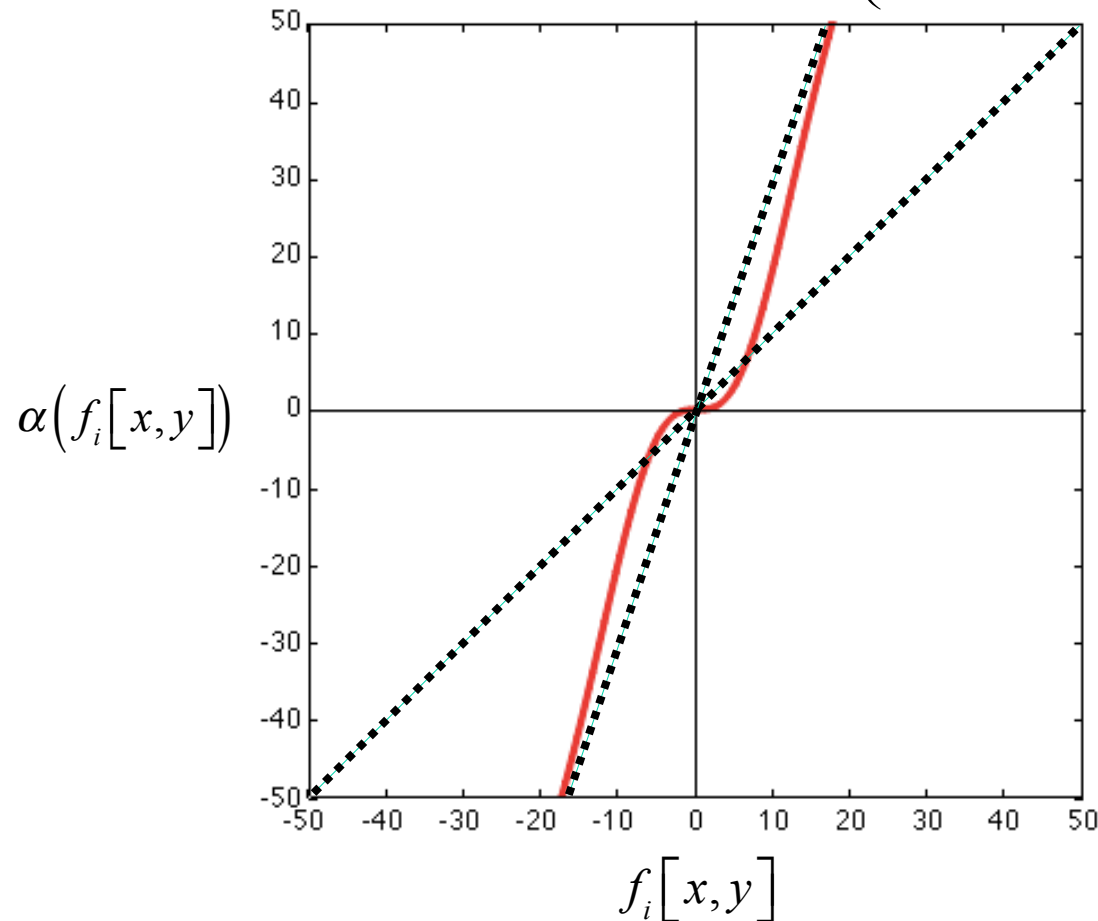

Example:

$$m = 3$$

$$\gamma = 2$$

$$\tau = 10$$

Soft coring of highpass filtered images

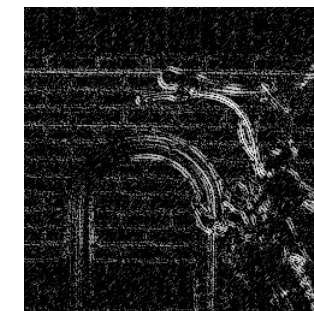
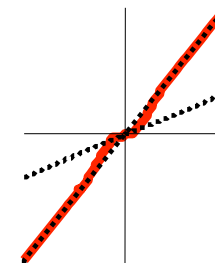
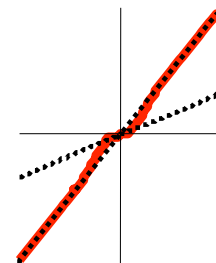
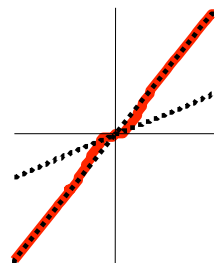
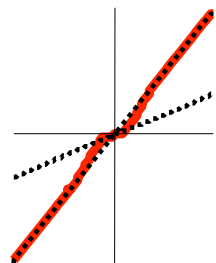
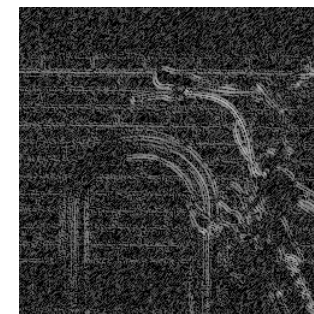
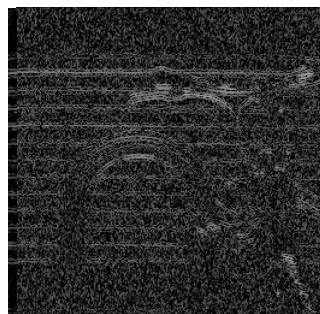

Linear vs. nonlinear noise reduction/sharpening



Noise reduction by
lowpass filter (linear)



Sharpening by highpass
filter (linear)



Combined noise reduction and
sharpening (nonlinear)

