

Keypoint detection

- Many applications benefit from features localized in (x,y)
(*image registration, panorama stitching, motion estimation + tracking, recognition ...*)
- Edges well localized only in one direction → detect corners?

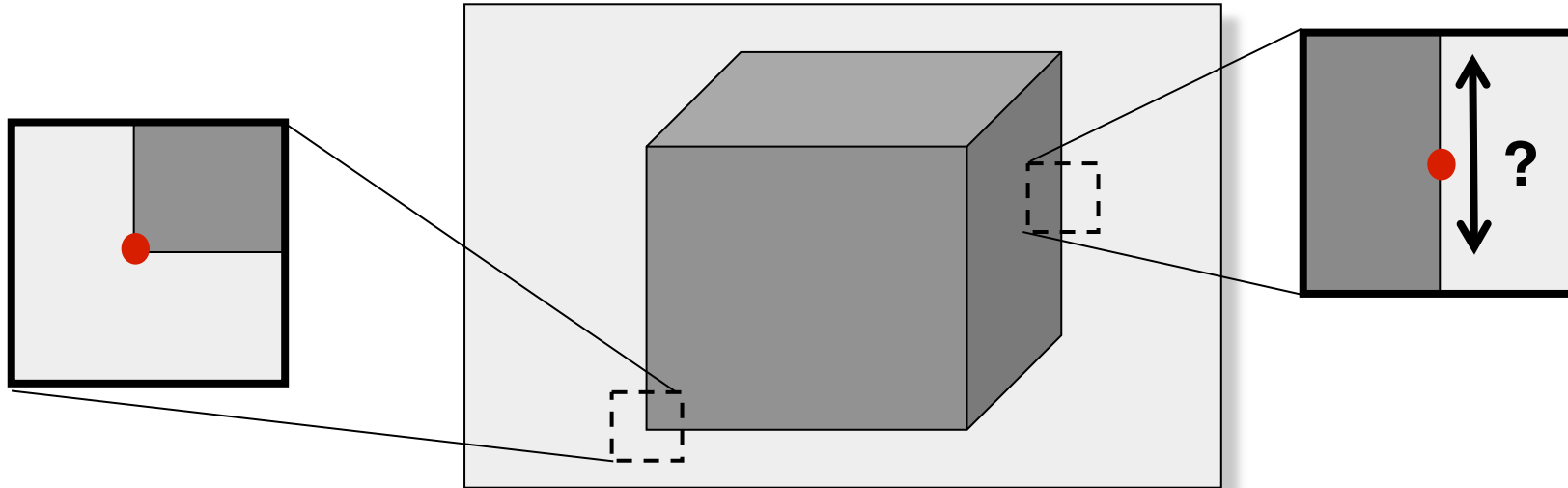

- Desirable properties of keypoint detector
 - Accurate localization
 - Invariance against shift, rotation, scale, brightness change
 - Robustness against noise, high repeatability

Keypoint detection

- Laplacian detector
- Determinant of Hessian detector
- Harris detector
- FAST detector

Laplacian keypoint detector

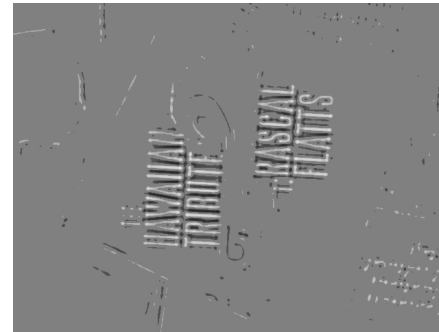
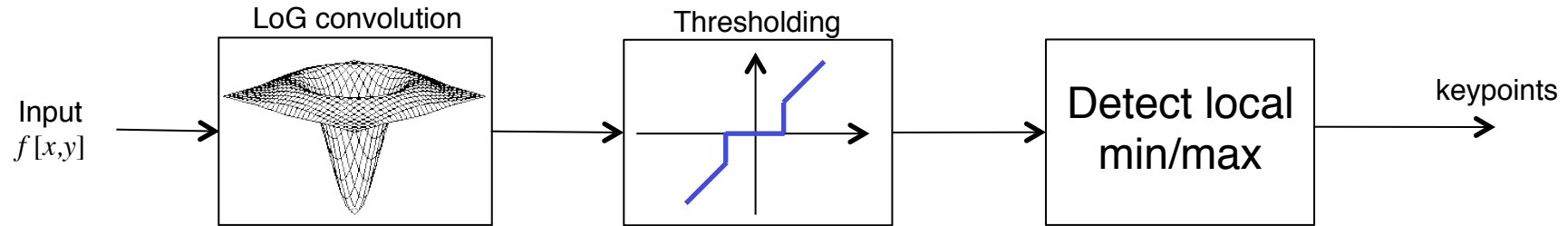

Input images

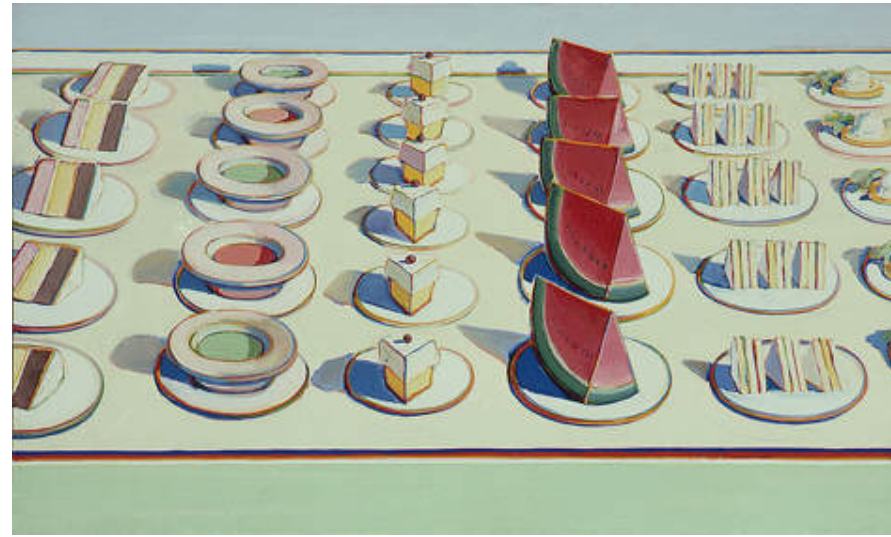

LoG response

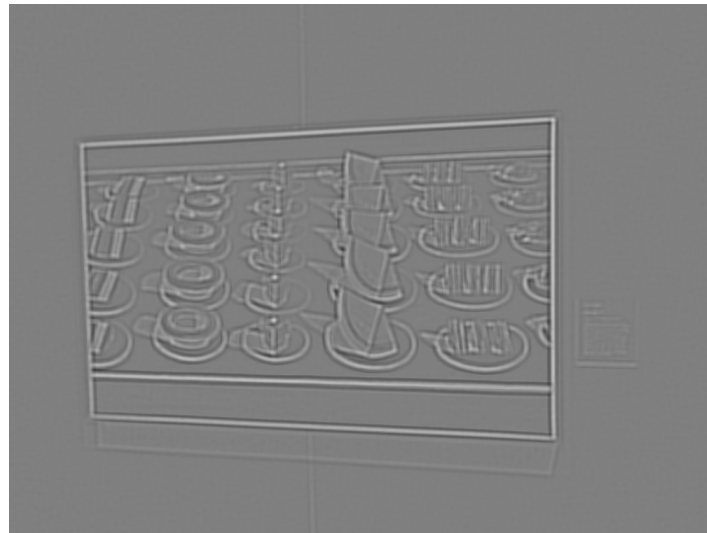
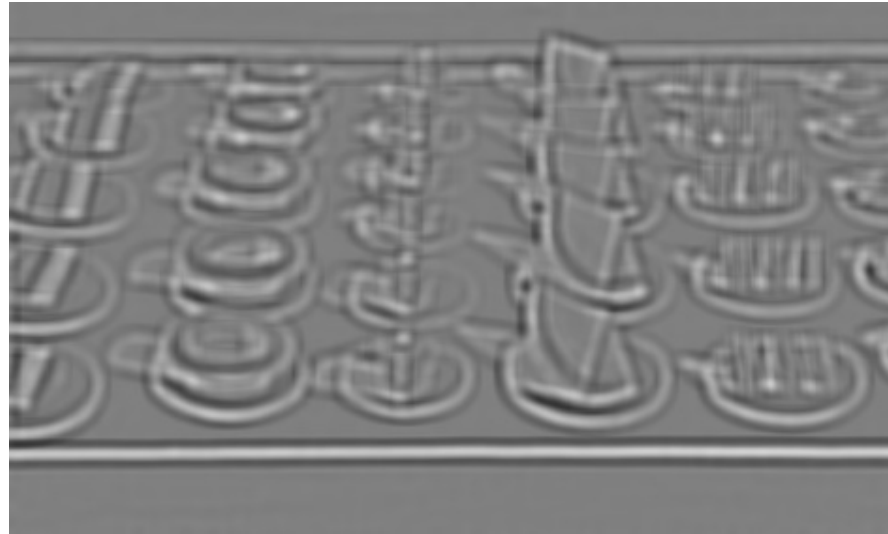

Thresholded LoG response

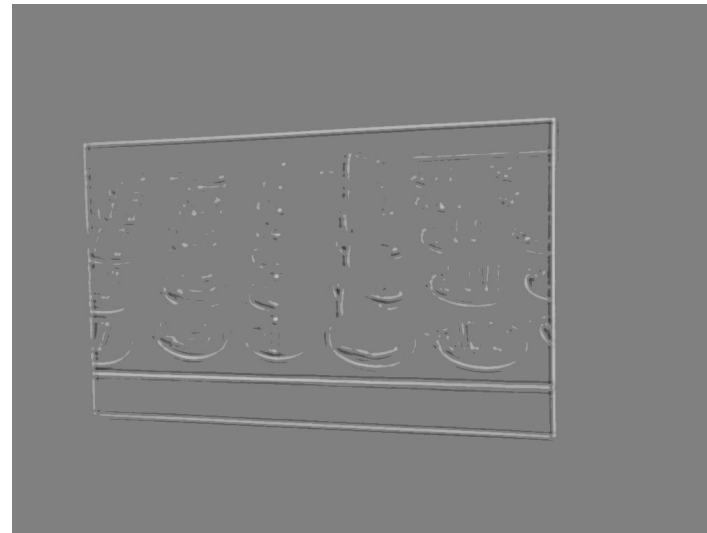
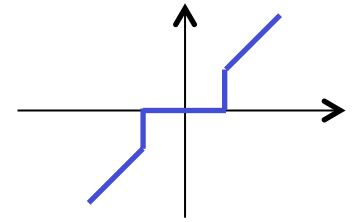
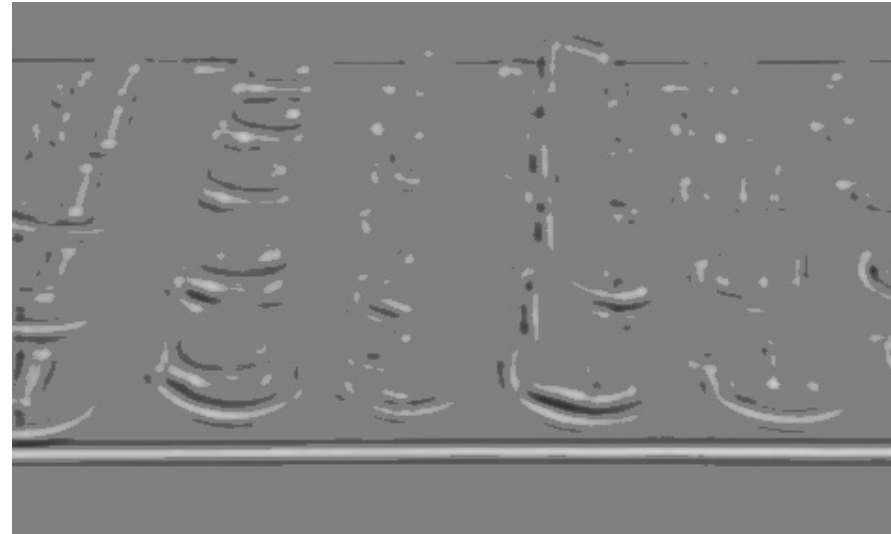
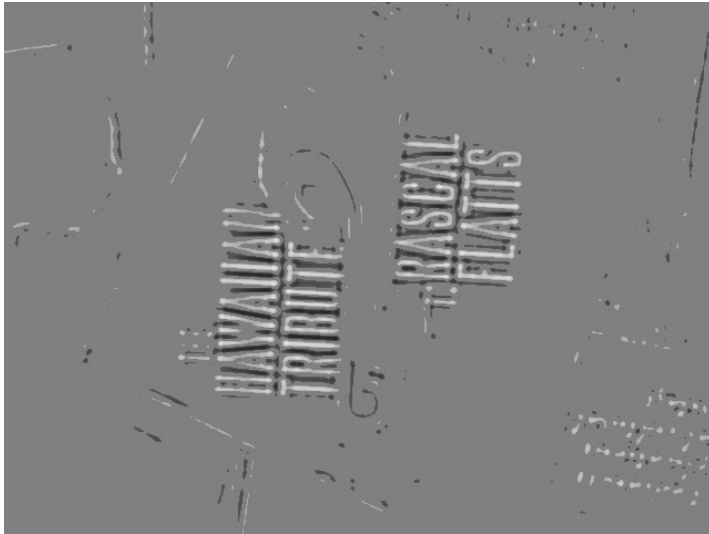

Local extrema of thresholded LoG response

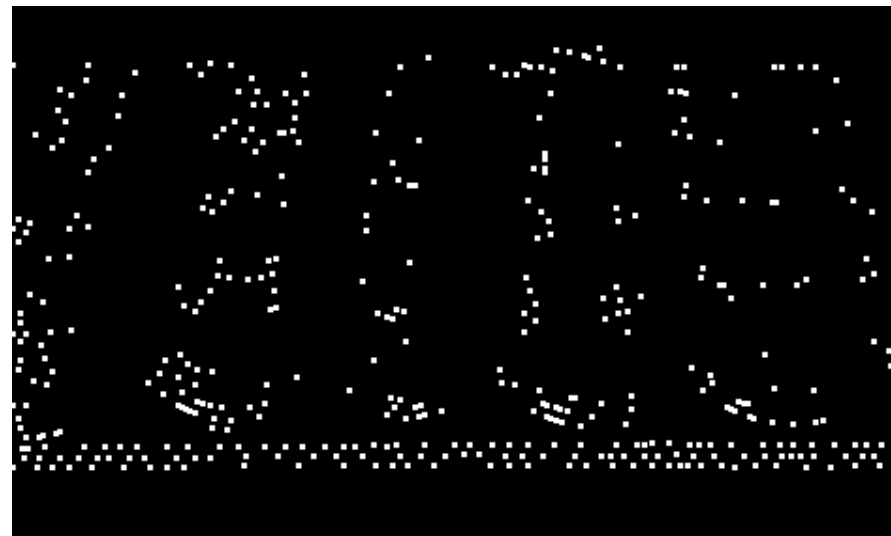

Superimposed LoG keypoints

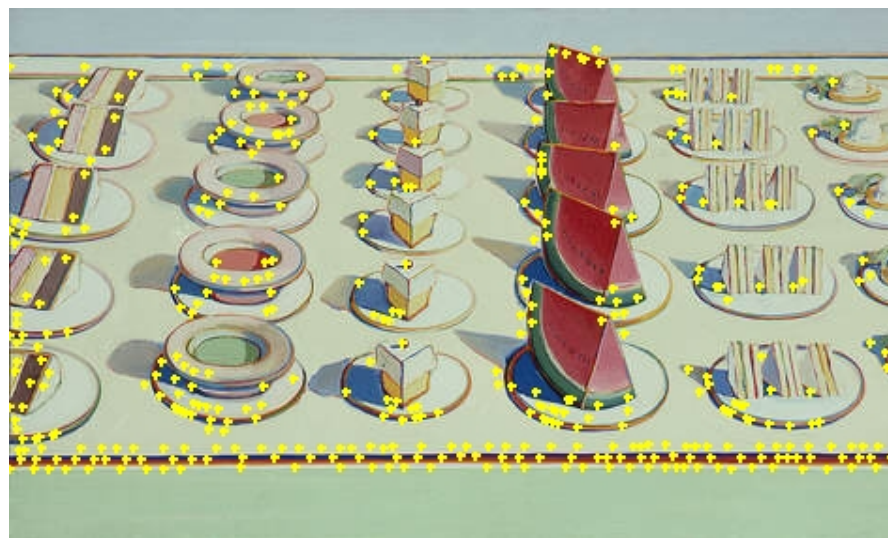

500 strongest keypoints

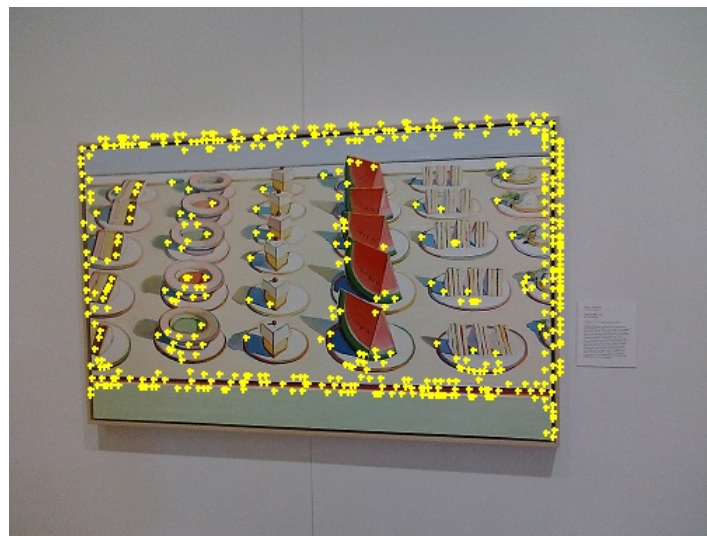
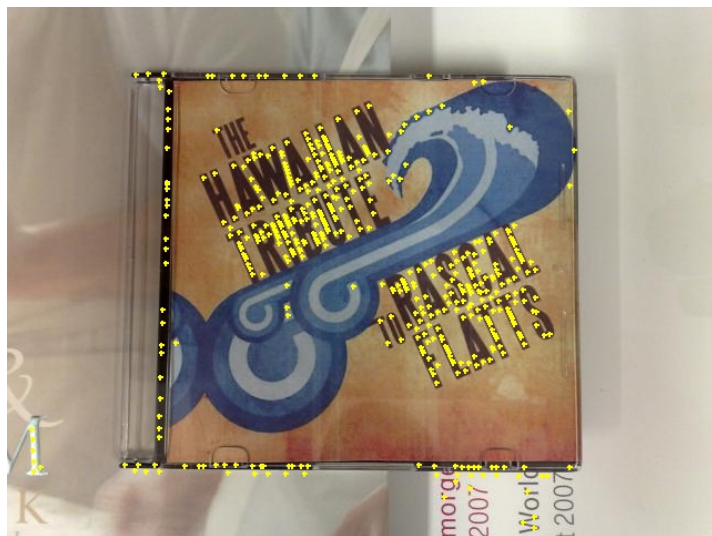

Determinant of Hessian keypoint detector

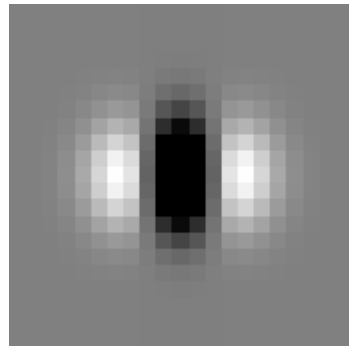

D_{xx}

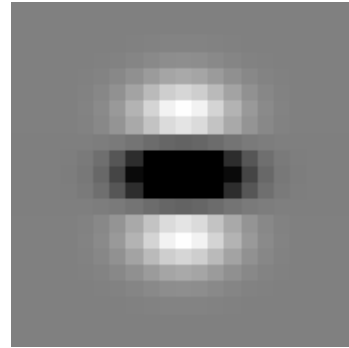

D_{yy}

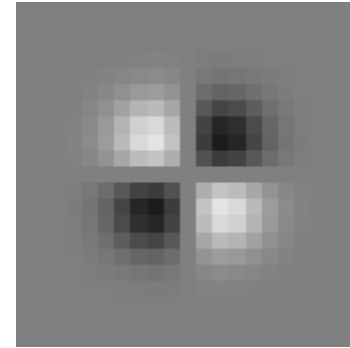

D_{xy}

$$\mathbf{H}[x,y] = \begin{bmatrix} f_{xx}[x,y] & f_{xy}[x,y] \\ f_{xy}[x,y] & f_{yy}[x,y] \end{bmatrix}$$
$$= \begin{bmatrix} D_{xx}[x,y] * f[x,y] & D_{xy}[x,y] * f[x,y] \\ D_{xy}[x,y] * f[x,y] & D_{yy}[x,y] * f[x,y] \end{bmatrix}$$

$$\det \mathbf{H}[x,y] = f_{xx}[x,y]f_{yy}[x,y] - (f_{xy}[x,y])^2$$



Input images

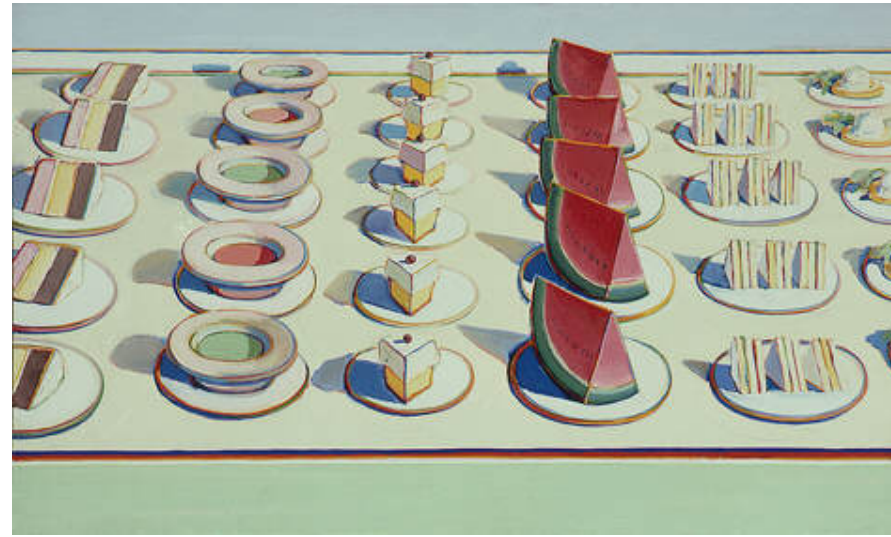

DoH response

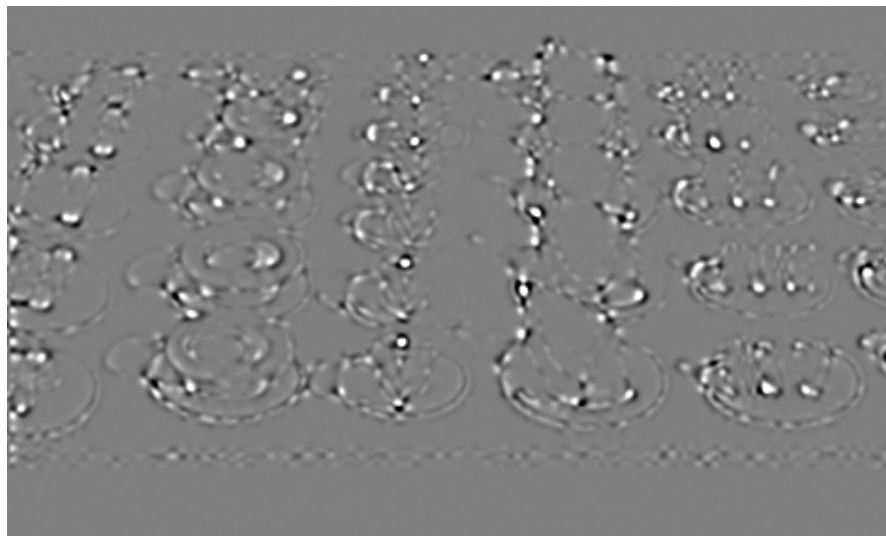
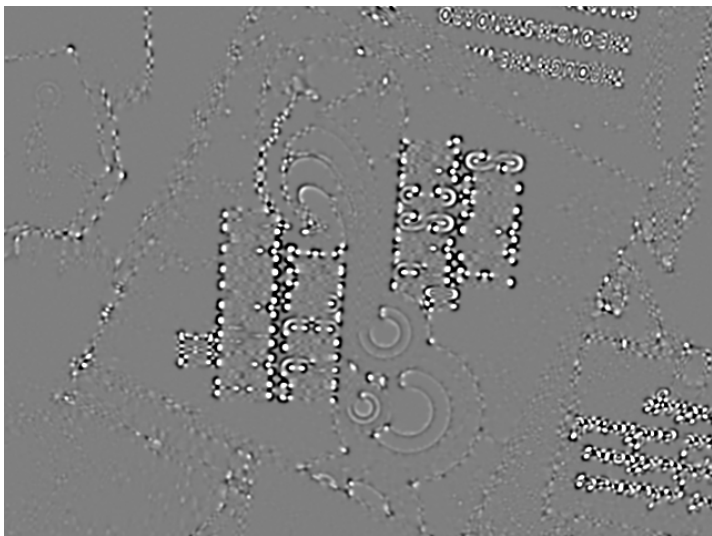

Thresholded DoH response

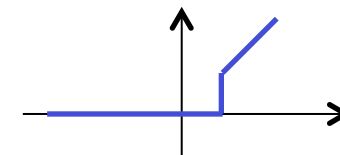
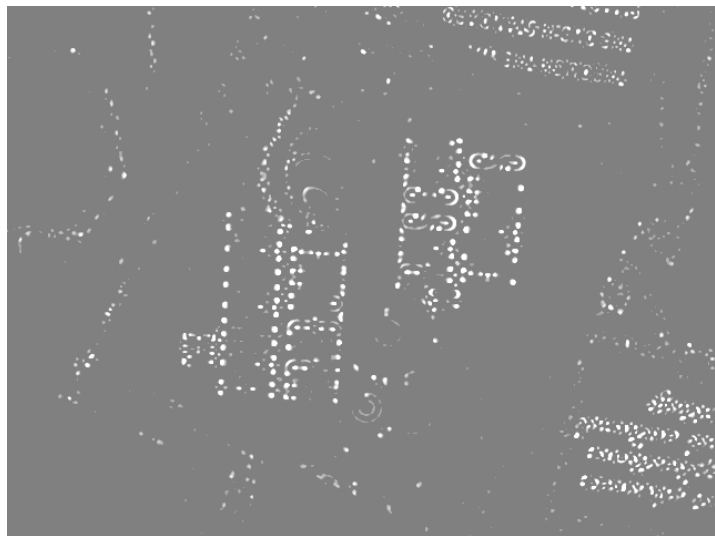

Local maxima of DoH response

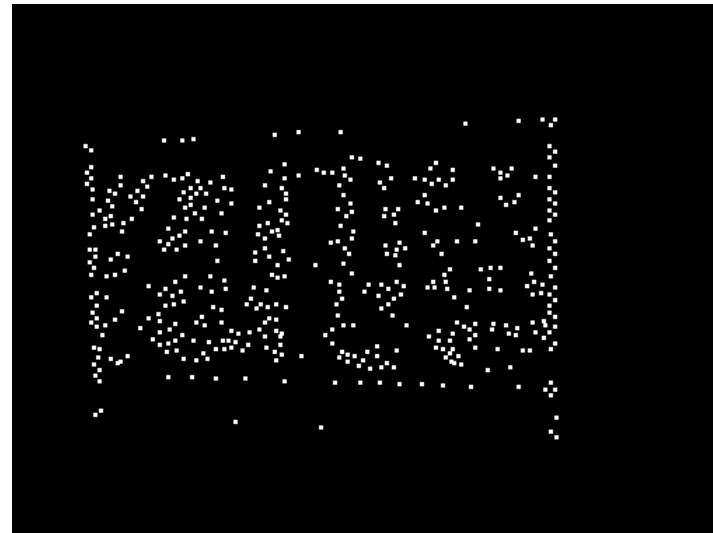
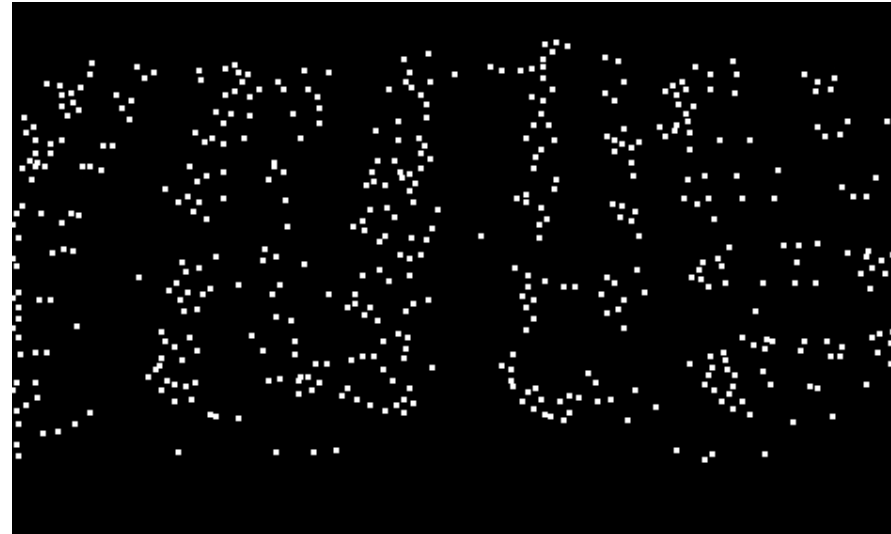

Superimposed DoH keypoints

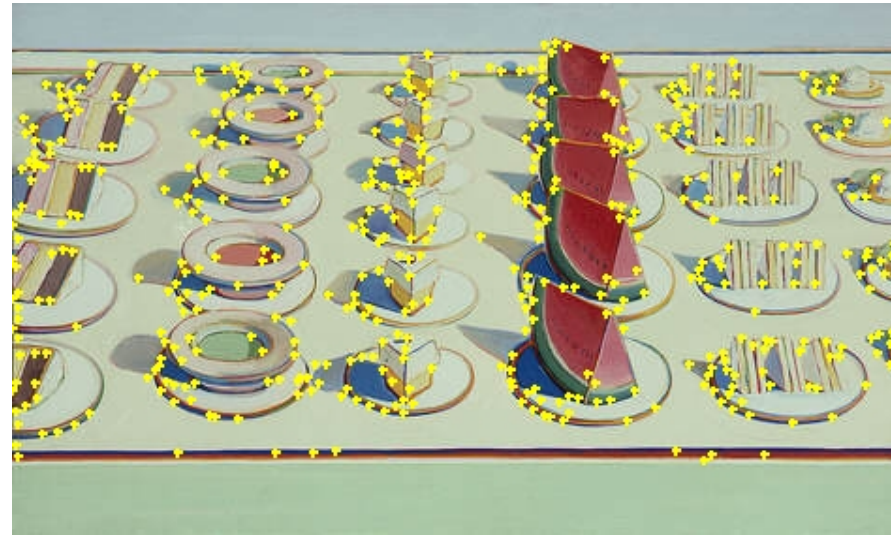

500 strongest keypoints

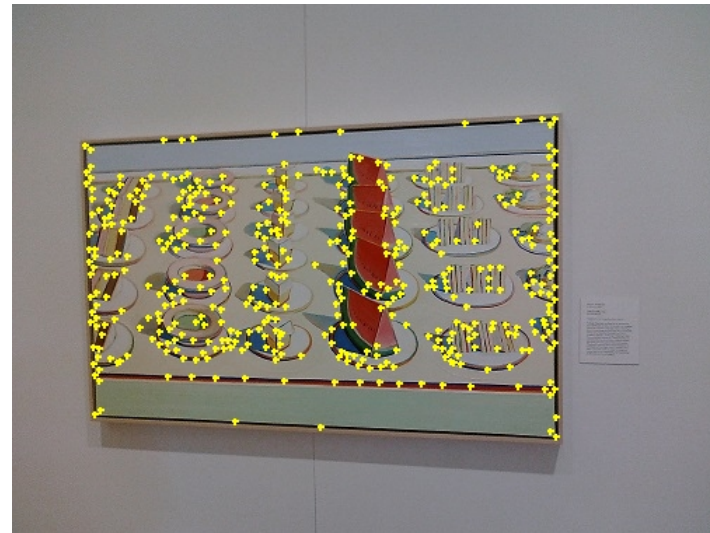
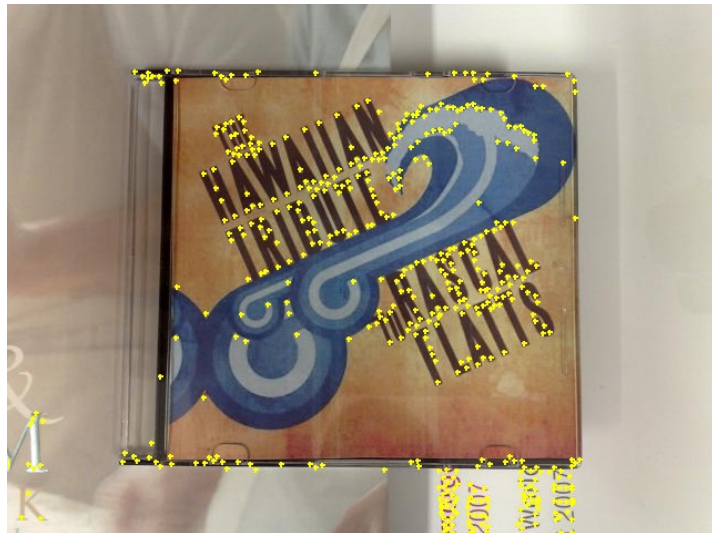

What patterns can be localized most accurately?

- Local displacement sensitivity (assuming continuous $f(x,y)$)

$$S(\Delta x, \Delta y) = \sum_{(x,y) \in \text{window}} [f(x,y) - f(x + \Delta x, y + \Delta y)]^2$$

- Linear approximation for small $\Delta x, \Delta y$

$$f(x + \Delta x, y + \Delta y) \approx f(x, y) + f_x(x, y)\Delta x + f_y(x, y)\Delta y$$

$f_x(x, y)$ – horizontal image gradient
 $f_y(x, y)$ – vertical image gradient

$$\begin{aligned} S(\Delta x, \Delta y) &\approx \sum_{(x,y) \in \text{window}} \left[\begin{pmatrix} f_x(x, y) & f_y(x, y) \end{pmatrix} \begin{pmatrix} \Delta x \\ \Delta y \end{pmatrix} \right]^2 \\ &= \begin{pmatrix} \Delta x & \Delta y \end{pmatrix} \left(\sum_{(x,y) \in \text{window}} \begin{bmatrix} f_x^2(x, y) & f_x(x, y)f_y(x, y) \\ f_x(x, y)f_y(x, y) & f_y^2(x, y) \end{bmatrix} \right) \begin{pmatrix} \Delta x \\ \Delta y \end{pmatrix} \\ &= \begin{pmatrix} \Delta x & \Delta y \end{pmatrix} \mathbf{M} \begin{pmatrix} \Delta x \\ \Delta y \end{pmatrix} \end{aligned}$$

- Iso-sensitivity curves are ellipses

Harris detector

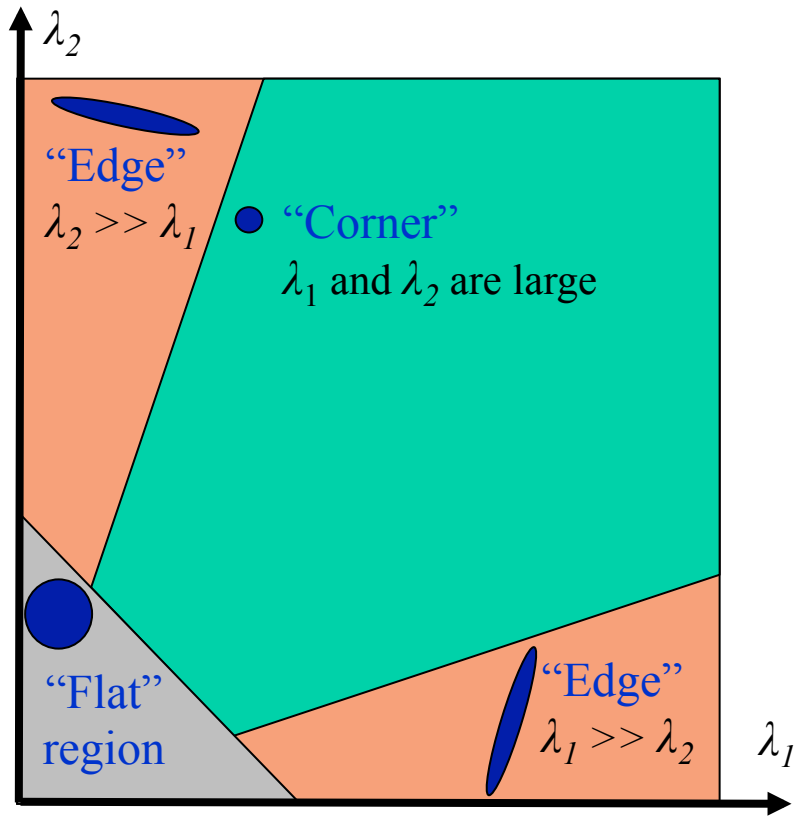

Based on eigenvalues λ_1, λ_2 of “structure matrix”
(aka “normal matrix” aka “second-moment matrix”)

$$\mathbf{M} = \begin{bmatrix} \sum_{[x,y] \in \text{window}} f_x^2[x,y] & \sum_{[x,y] \in \text{window}} f_x[x,y] f_y[x,y] \\ \sum_{[x,y] \in \text{window}} f_x[x,y] f_y[x,y] & \sum_{[x,y] \in \text{window}} f_y^2[x,y] \end{bmatrix}$$

$f_x[x,y]$ – horizontal image gradient
 $f_y[x,y]$ – vertical image gradient

Harris cornerness

$$C = \det(\mathbf{M}) - k \cdot (\text{trace}(\mathbf{M}))^2 = \lambda_1 \lambda_2 - k \cdot (\lambda_1 + \lambda_2)^2$$

$k = 0.2$

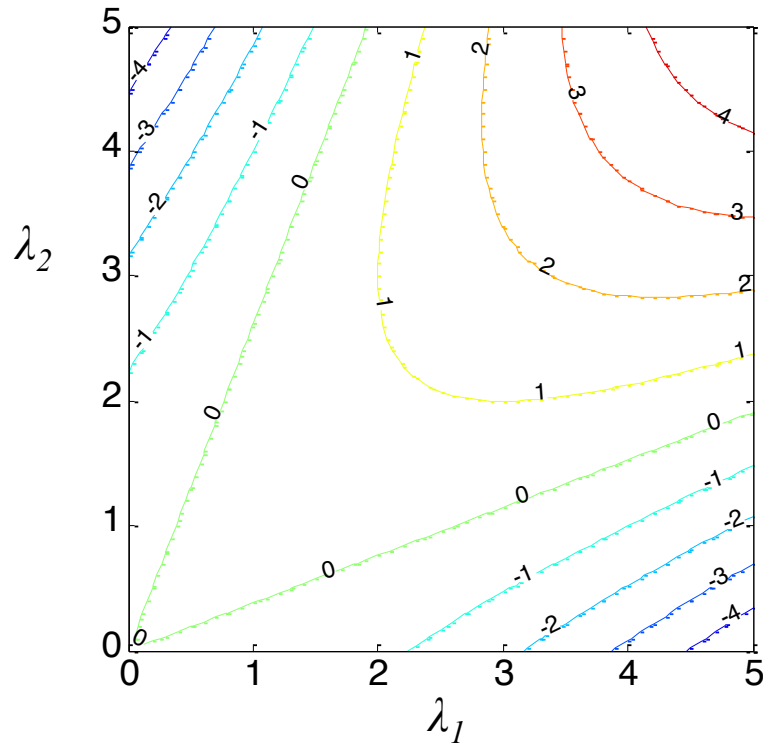

$k = 0.05$

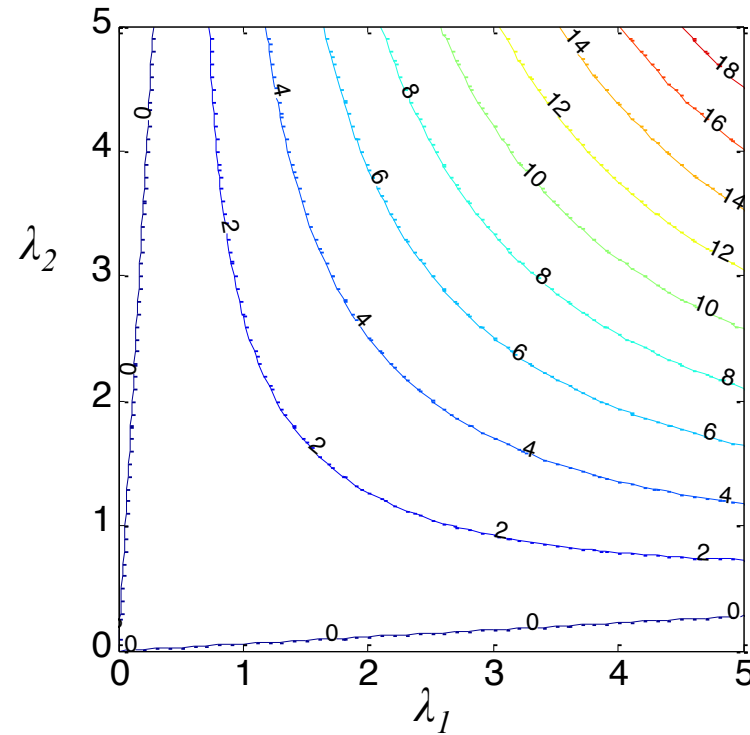

Input images

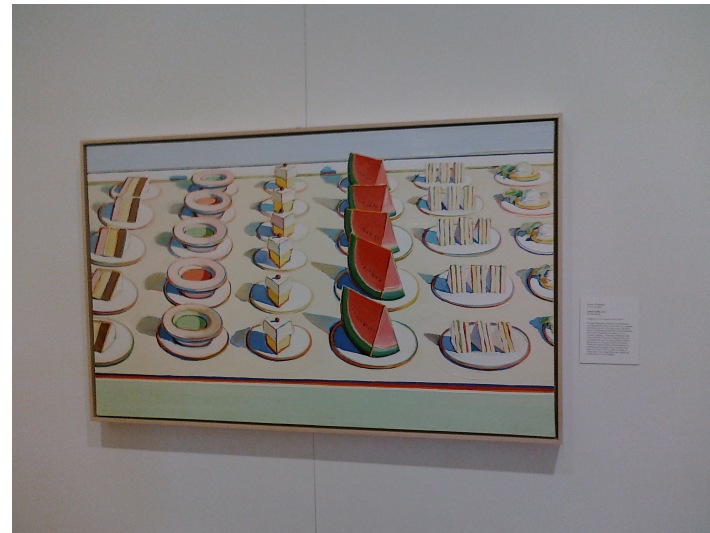
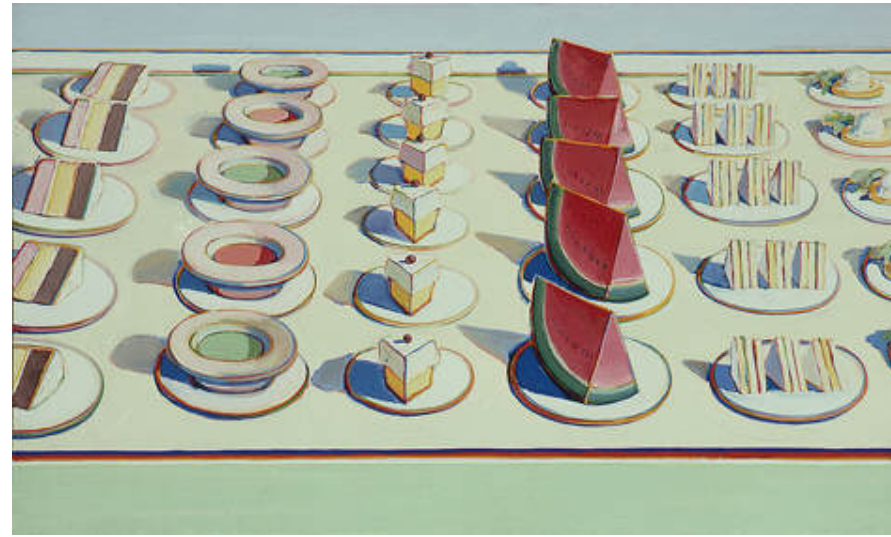

Harris cornerness

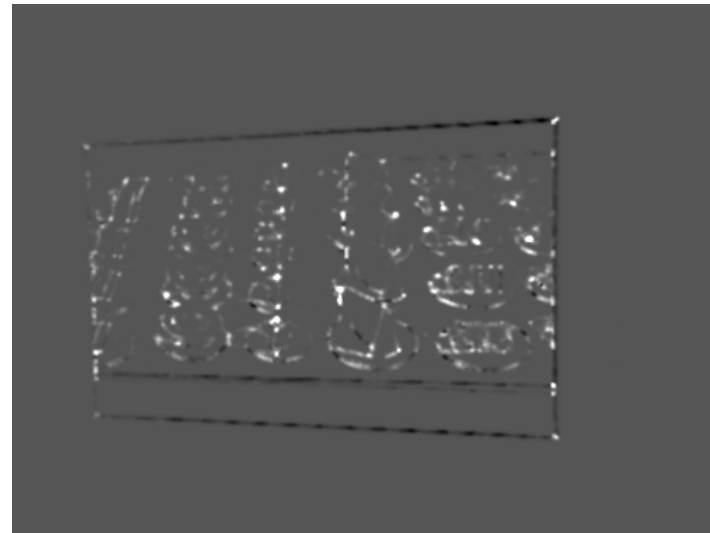
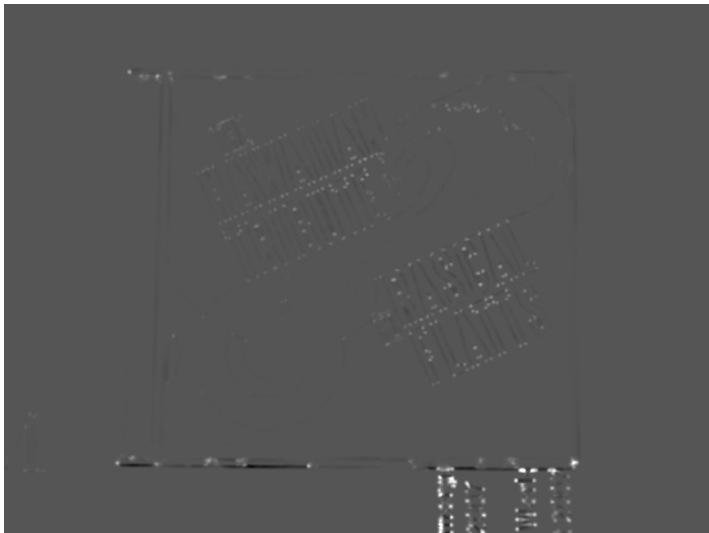
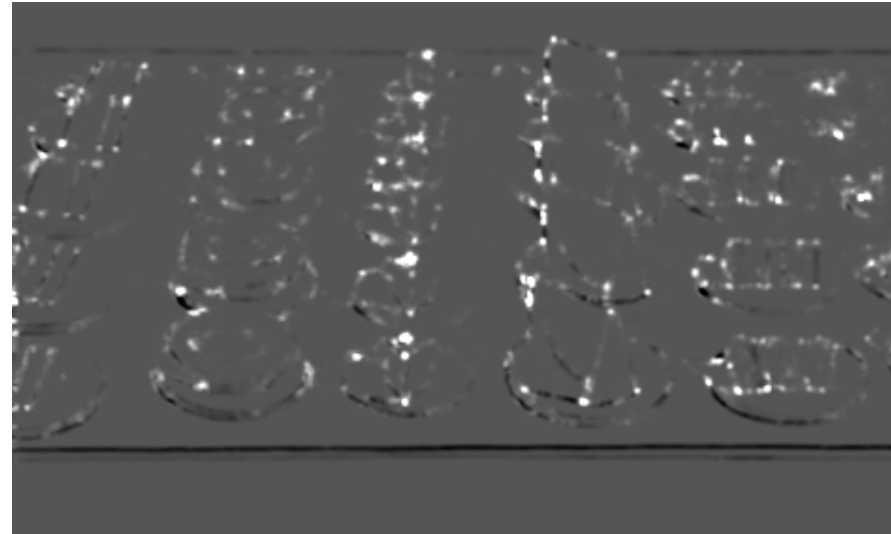
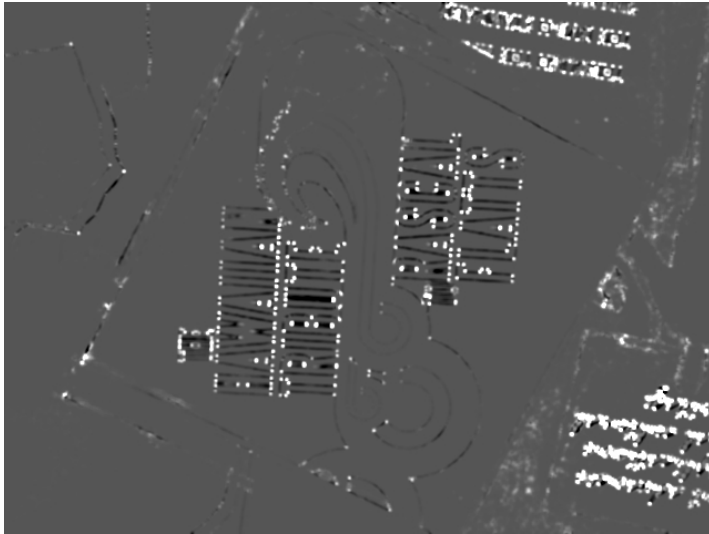

Thresholded cornerness

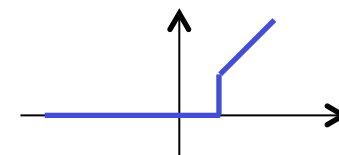
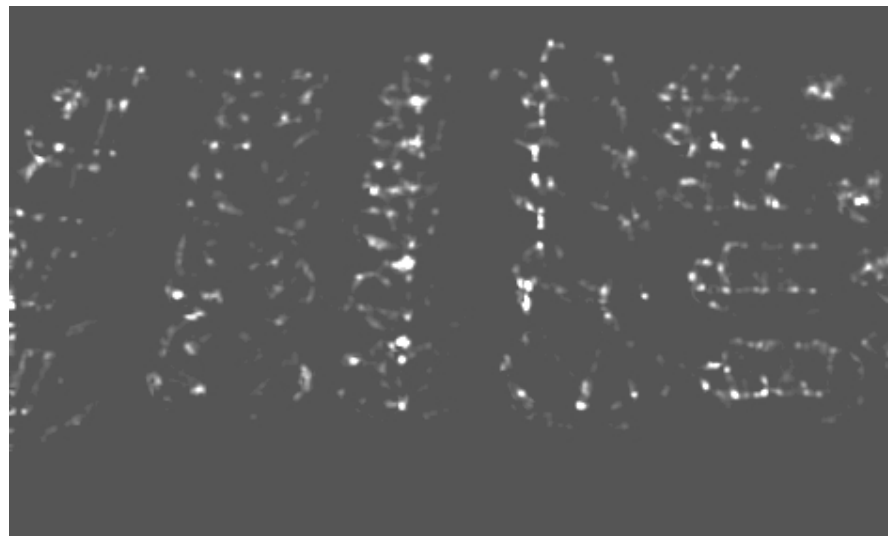
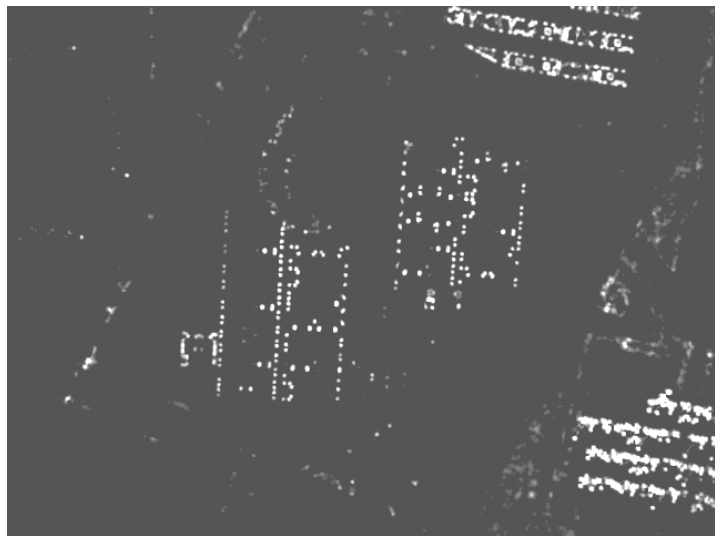

Local maxima of cornerness

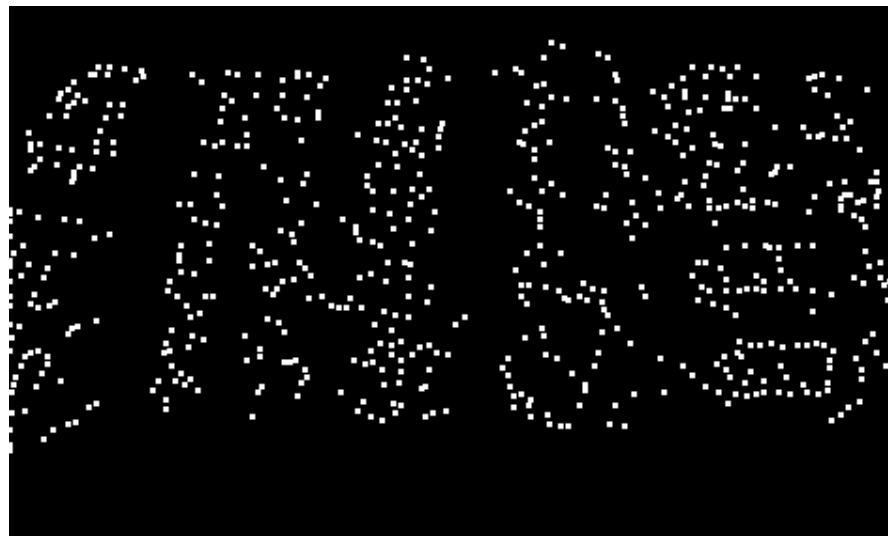

Superimposed Harris keypoints

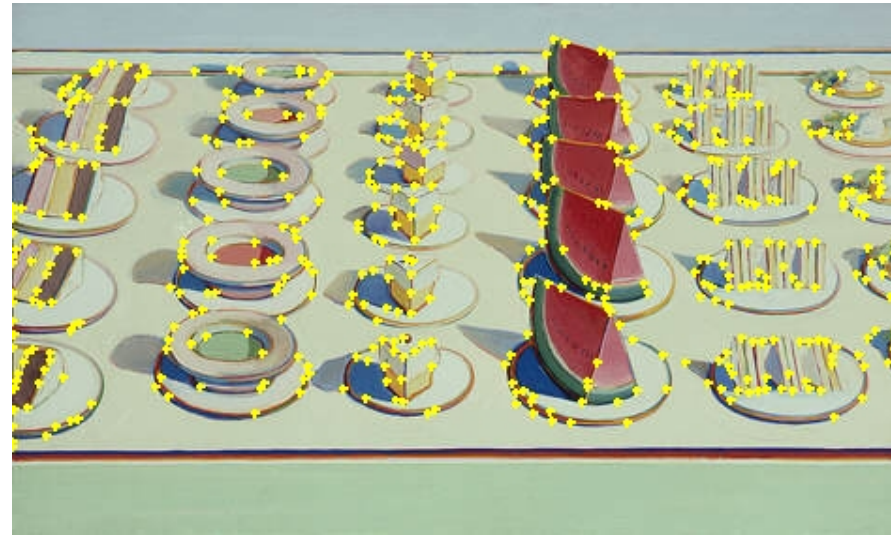

500 strongest keypoints

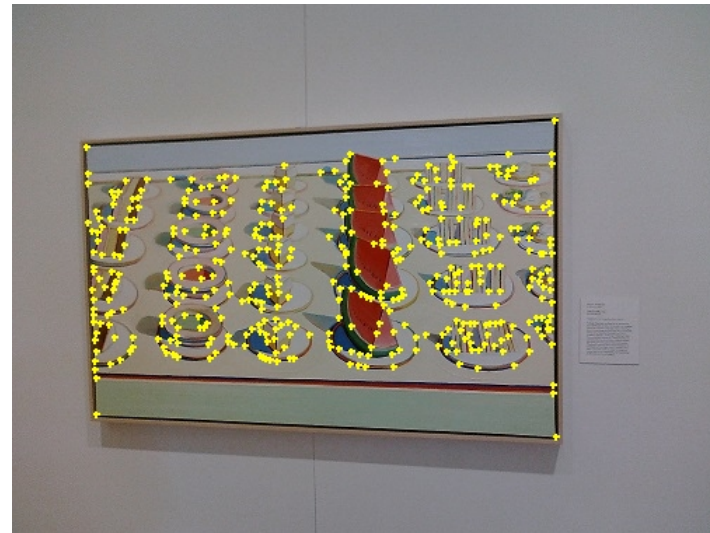
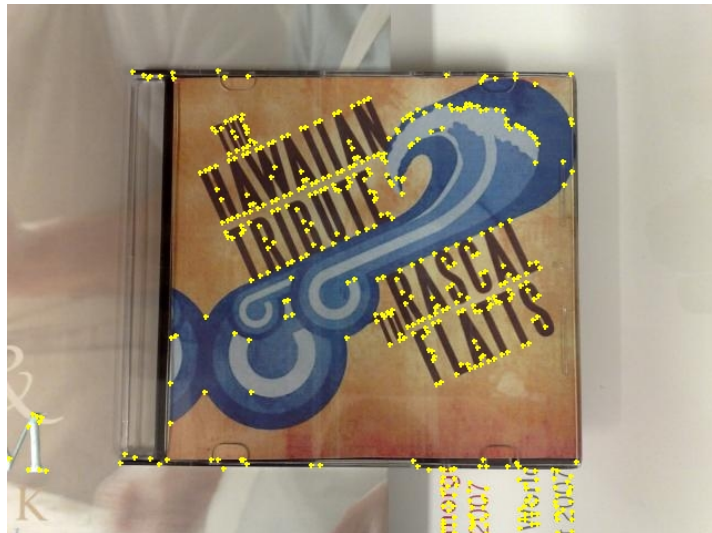

Robustness of Harris detector

- Invariant to brightness offset: $f[x,y] \rightarrow f[x,y] + c$

- Invariant to shift and rotation

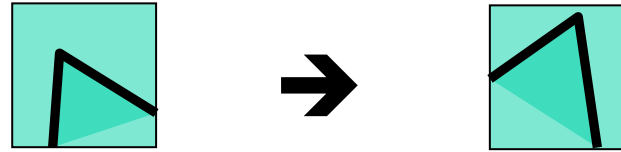

- Not invariant to scaling

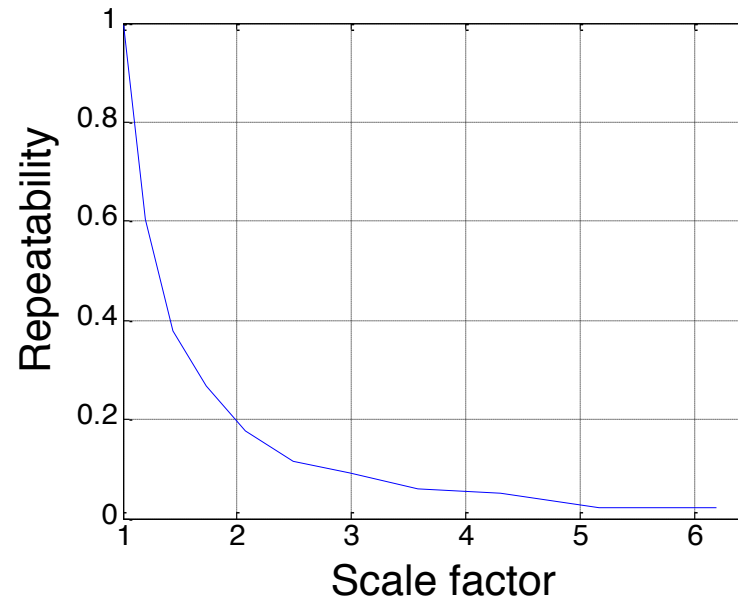
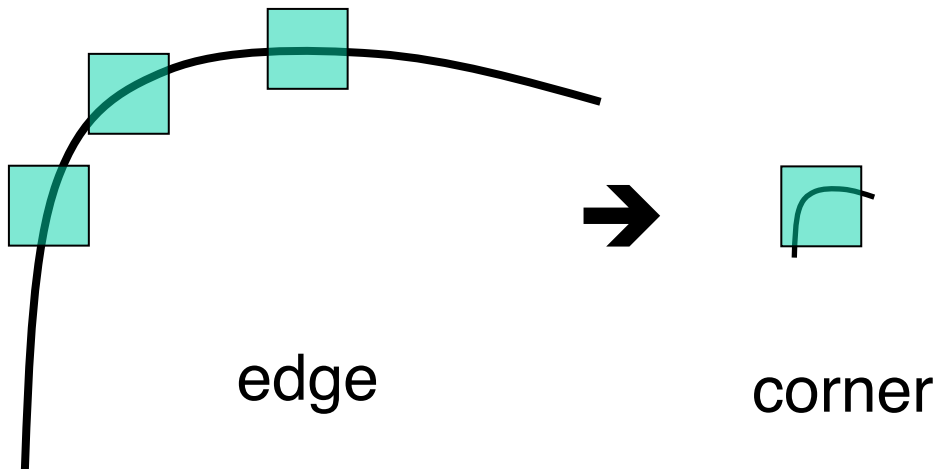

Features from Accelerated Segment Test (FAST)

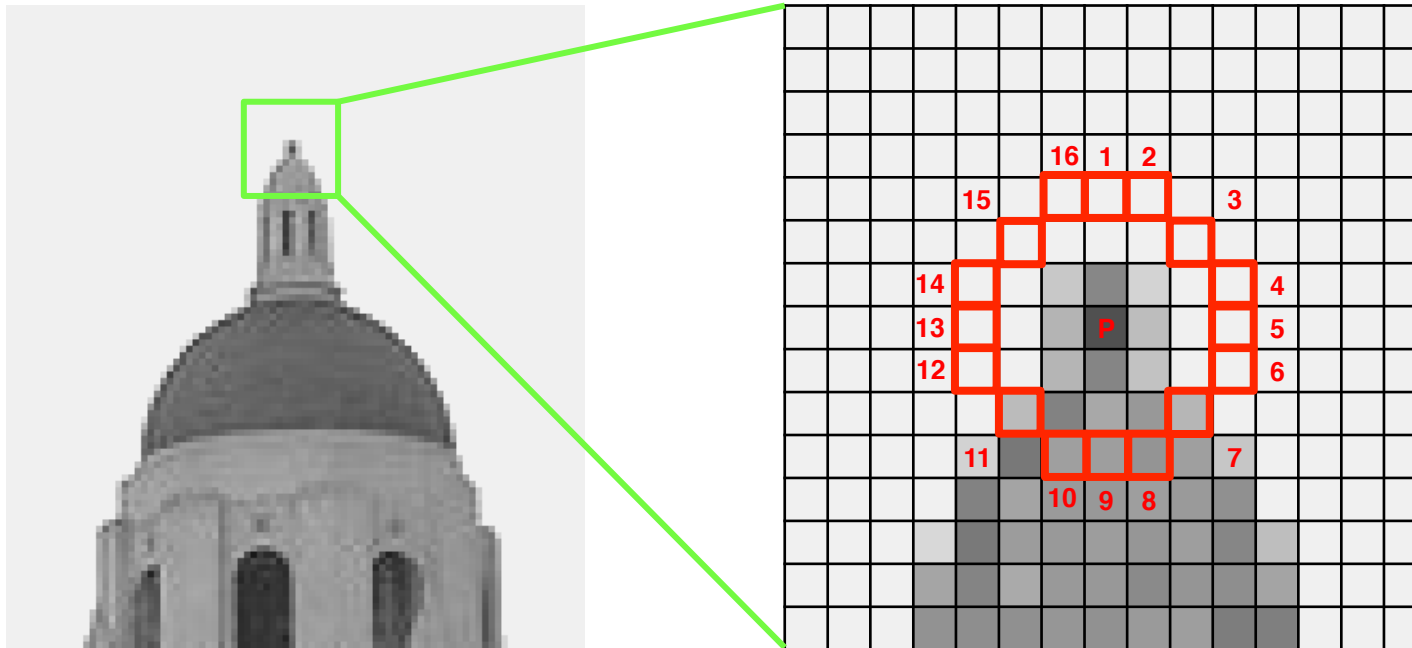

- Compare “nucleus” p to circle of sixteen pixels
- Nucleus is feature point, iff at least $n=9$ contiguous circle pixels are either all brighter, or all darker, by θ
- Optimize pixel comparisons to reject non-corners early

Input images

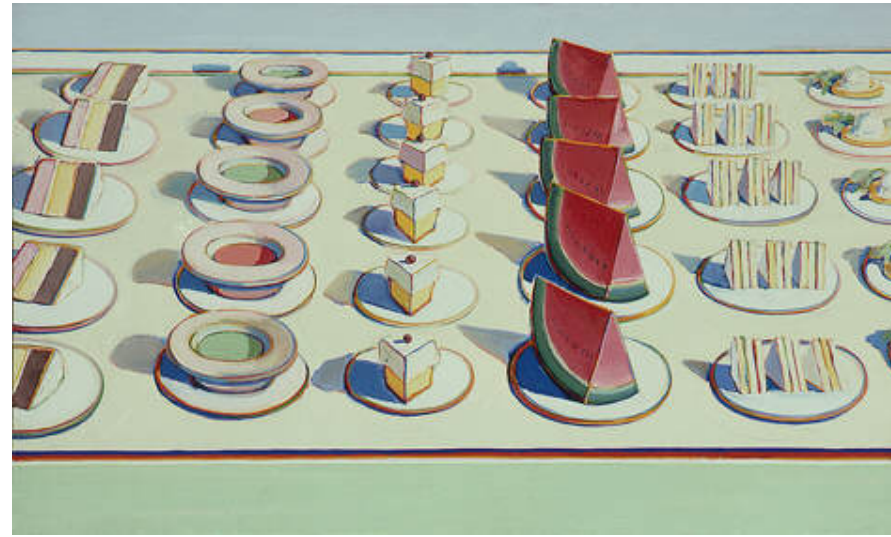

FAST corners superimposed

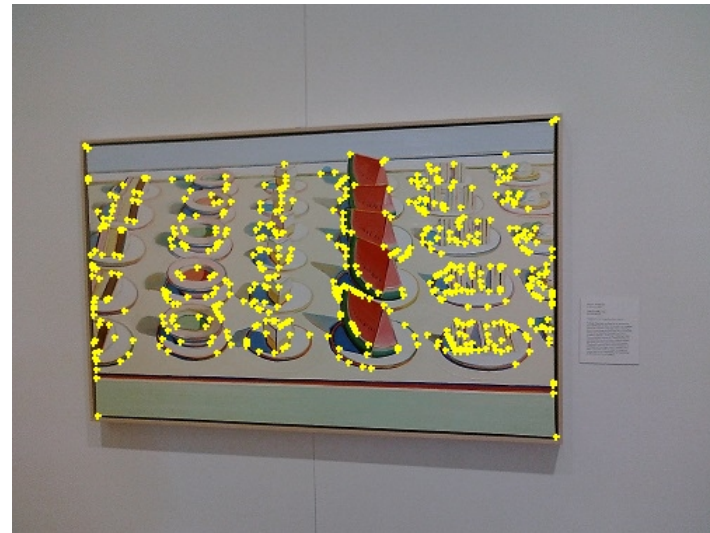
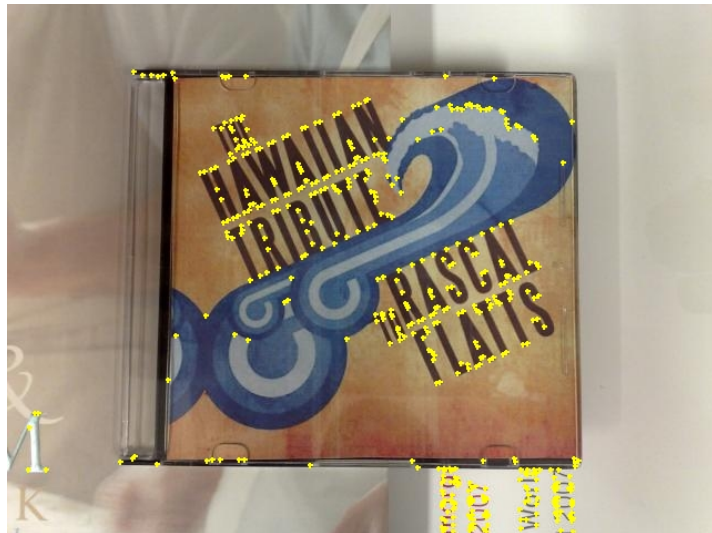
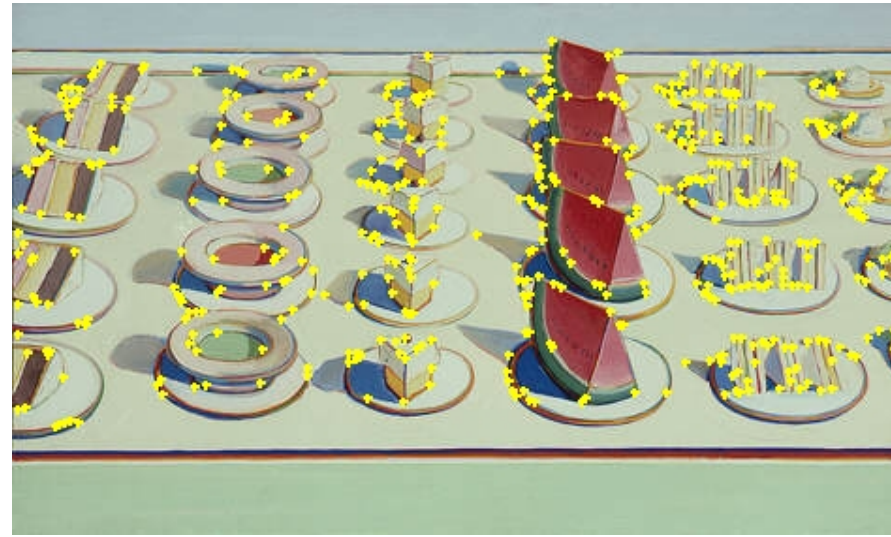

FAST corner detection on smartphone

FAST keypoint tracking on smartphone