

# Nonlinear noise reduction/sharpening

- Noise reduction: smooth the image, lowpass filtering
- Deblurring: sharpen edges, highpass filtering
- How can both be achieved simultaneously?
- Key insight: large amplitude of highpass filtered image indicates presence of edge

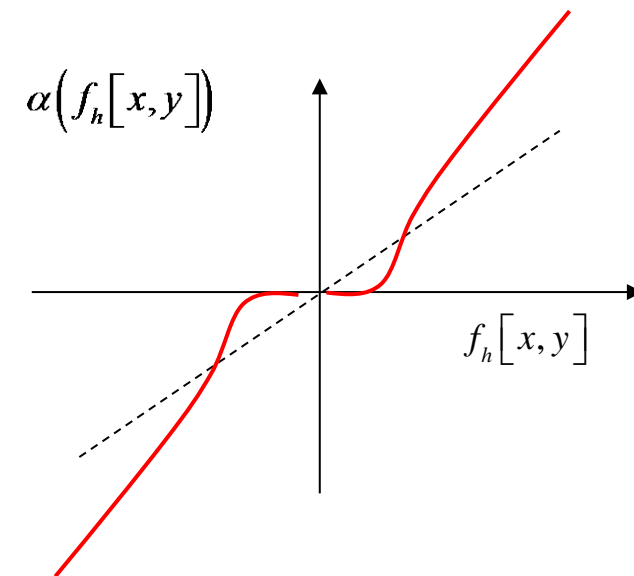
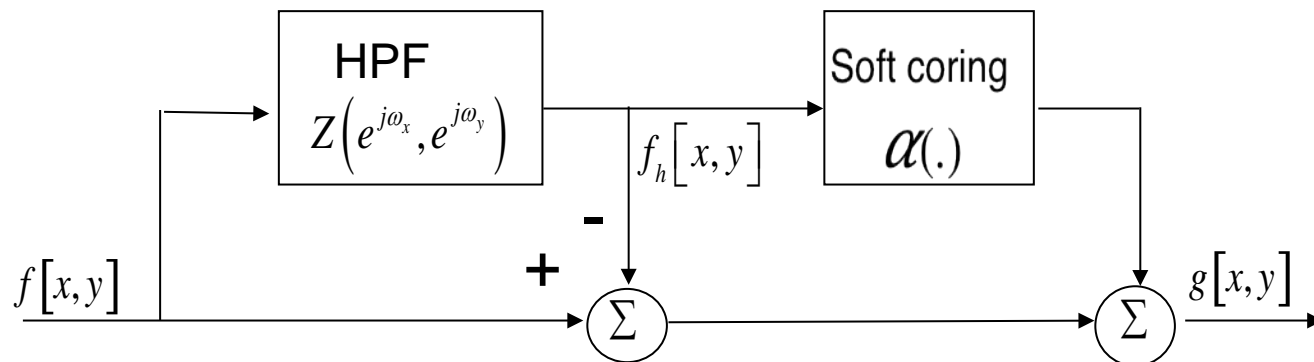

- Can be extended to multiple HPFs

# Nonlinear noise reduction/sharpening (cont.)

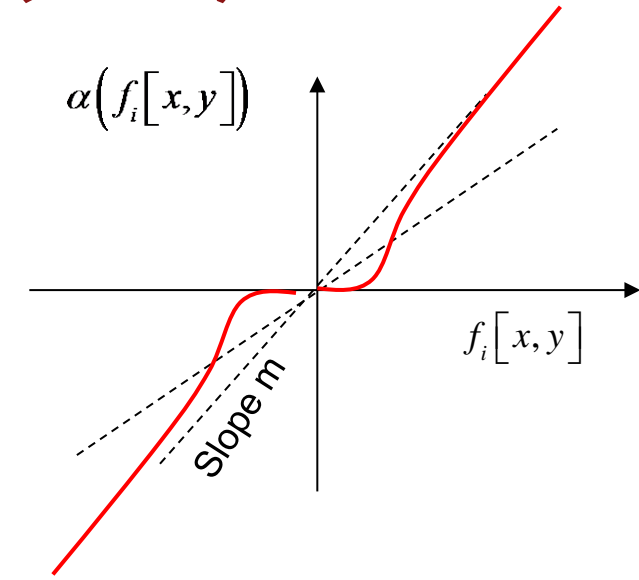
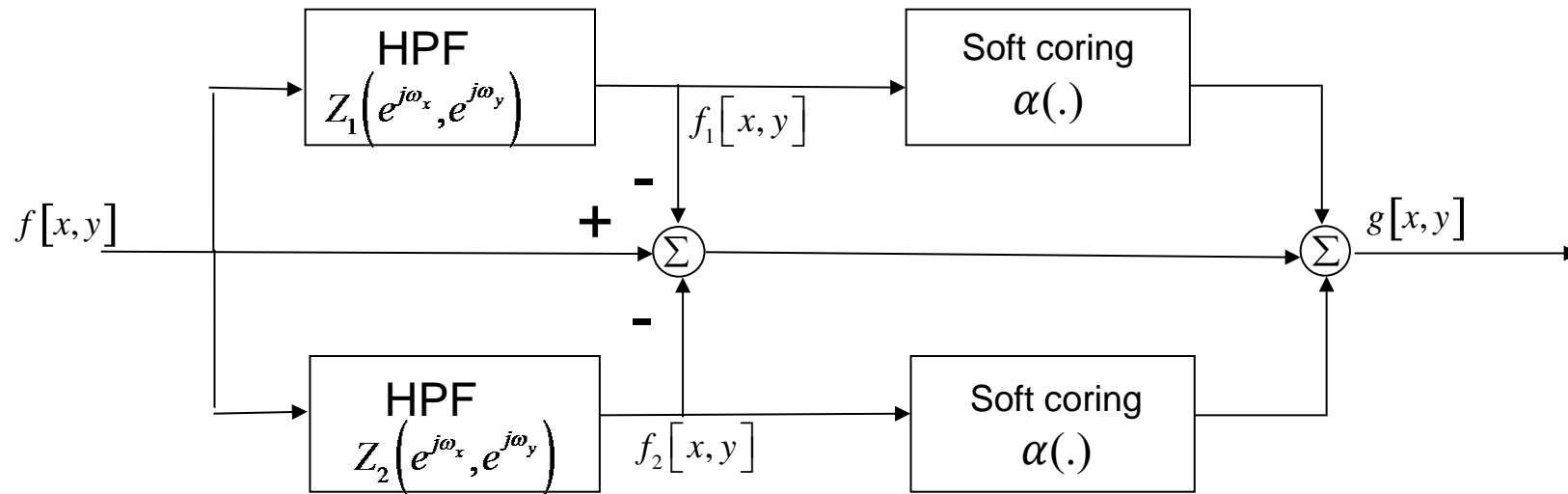

- Flat areas:  $\alpha \approx 0 \rightarrow H(e^{j\omega_x}, e^{j\omega_y}) \approx 1 - Z_1(e^{j\omega_x}, e^{j\omega_y}) - Z_2(e^{j\omega_x}, e^{j\omega_y})$
- $f_1$  small;  $f_2$  large:  $H(e^{j\omega_x}, e^{j\omega_y}) \approx 1 - Z_1(e^{j\omega_x}, e^{j\omega_y}) + (m-1)Z_2(e^{j\omega_x}, e^{j\omega_y})$
- $f_1$  large;  $f_2$  small:  $H(e^{j\omega_x}, e^{j\omega_y}) \approx 1 + (m-1)Z_1(e^{j\omega_x}, e^{j\omega_y}) - Z_2(e^{j\omega_x}, e^{j\omega_y})$
- Both large:  $H(e^{j\omega_x}, e^{j\omega_y}) \approx 1 + (m-1)[Z_1(e^{j\omega_x}, e^{j\omega_y}) + Z_2(e^{j\omega_x}, e^{j\omega_y})]$

# Nonlinear noise reduction/sharpening example



blurred, noisy image

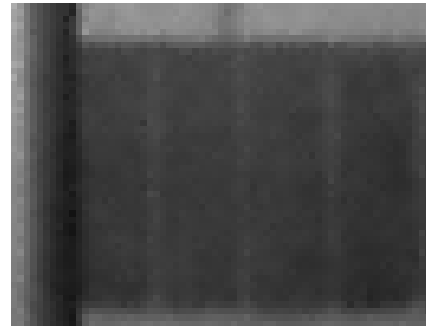
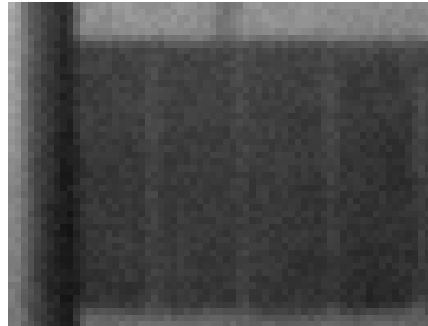
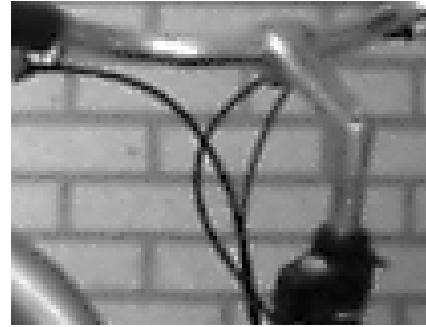
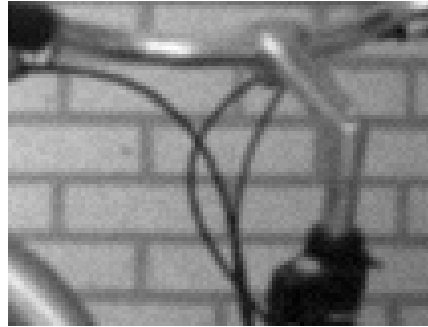

noise-reduced  
and sharpened



# Highpass filtered images

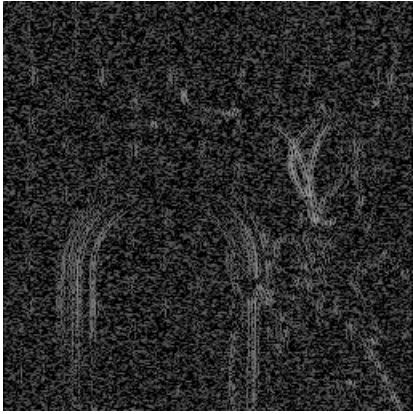

log magnitude of  
image filtered with

$$\begin{pmatrix} 0 & 0 & 0 \\ -0.5 & [1] & -0.5 \\ 0 & 0 & 0 \end{pmatrix}$$



log magnitude of  
image filtered with

$$\begin{pmatrix} 0 & -0.5 & 0 \\ 0 & [1] & 0 \\ 0 & -0.5 & 0 \end{pmatrix}$$

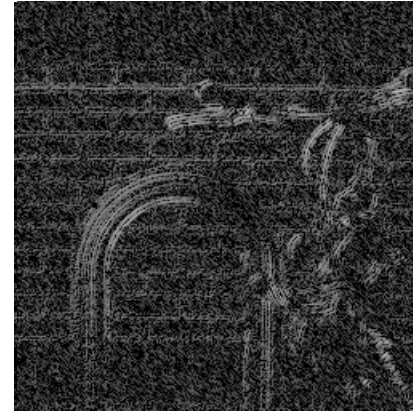

log magnitude of  
image filtered with

$$\begin{pmatrix} -0.5 & 0 & 0 \\ 0 & [1] & 0 \\ 0 & 0 & -0.5 \end{pmatrix}$$

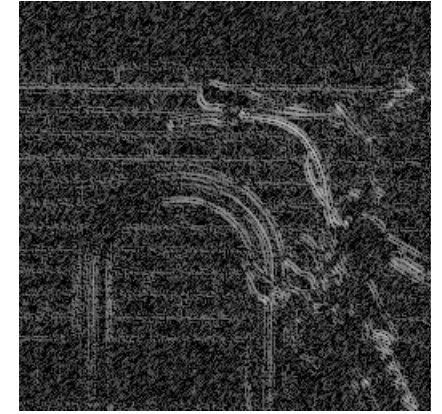

log magnitude of  
image filtered with

$$\begin{pmatrix} 0 & 0 & -0.5 \\ 0 & [1] & 0 \\ -0.5 & 0 & 0 \end{pmatrix}$$



# Soft coring function

$$\alpha(f_i[x,y]) = m \cdot f_i[x,y] \cdot \left( 1 - e^{-\frac{|f_i[x,y]|^\gamma}{\tau}} \right)$$

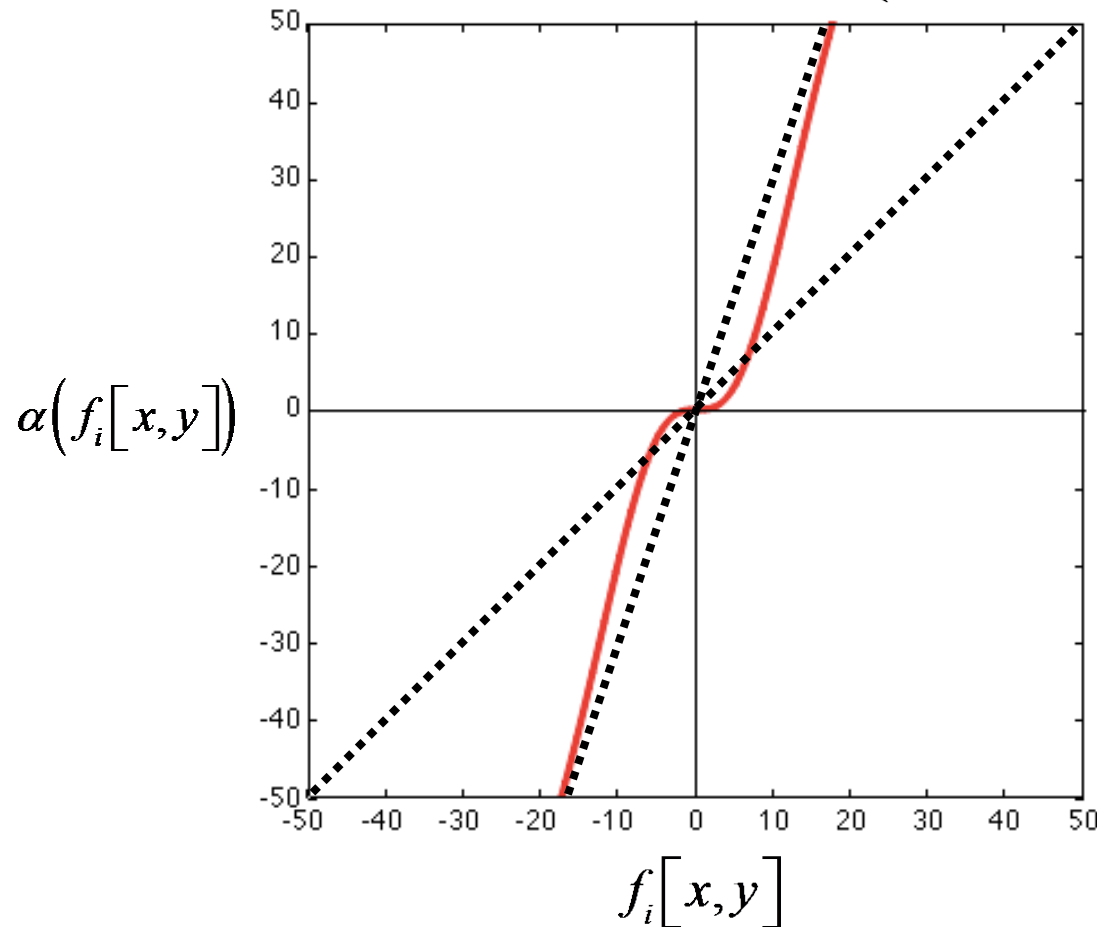

Example:

$$m = 3$$

$$\gamma = 2$$

$$\tau = 10$$

# Soft coring of highpass filtered images

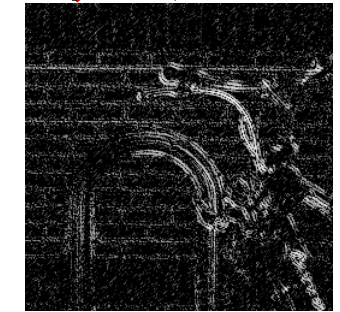
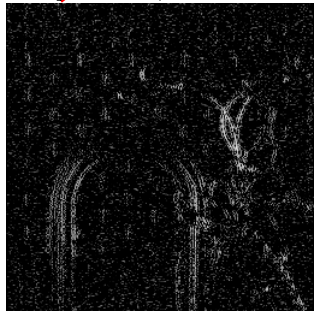
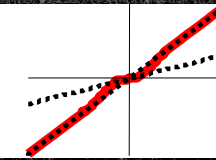
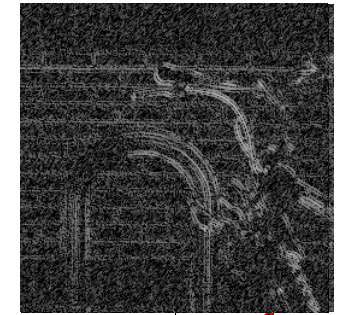
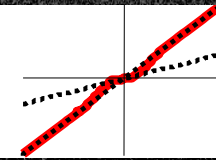
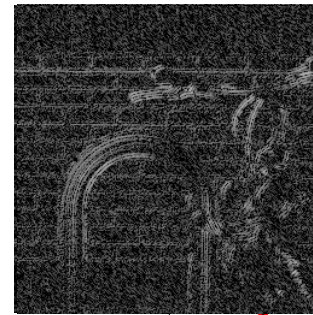
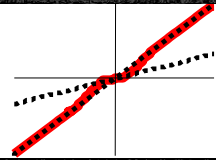
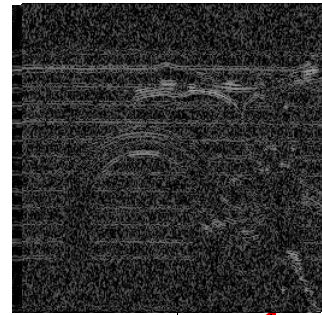
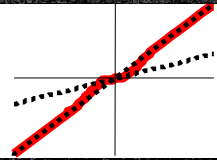
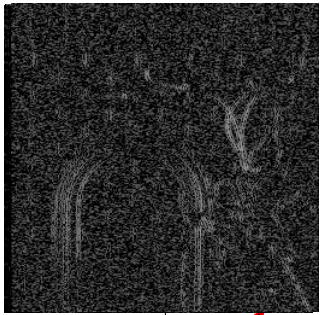

# Linear vs. nonlinear noise reduction/sharpening



Noise reduction by  
lowpass filter (linear)



Sharpening by highpass  
filter (linear)



Combined noise reduction and  
sharpening (nonlinear)

