

SIFT keypoint detection

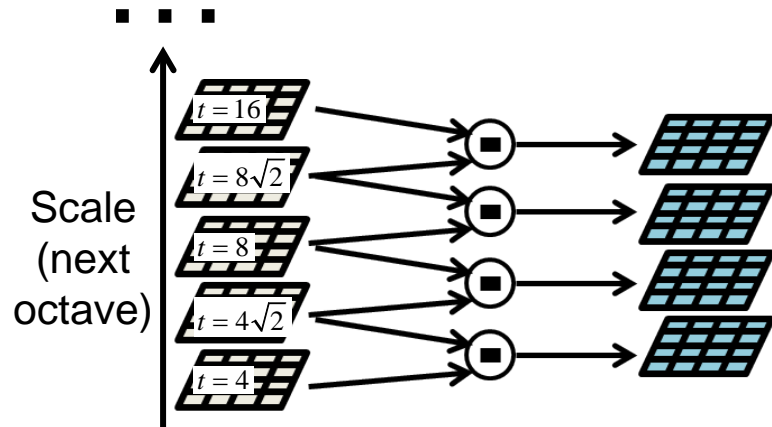

- SIFT - Scale-Invariant Feature Transform
- Decompose image into DoG scale-space representation
- Detect minima and maxima locally and across scales
- Fit 3-d quadratic function to localize extrema with sub-pixel/sub-scale accuracy [Brown, Lowe, 2002]
- Eliminate edge responses based on Hessian

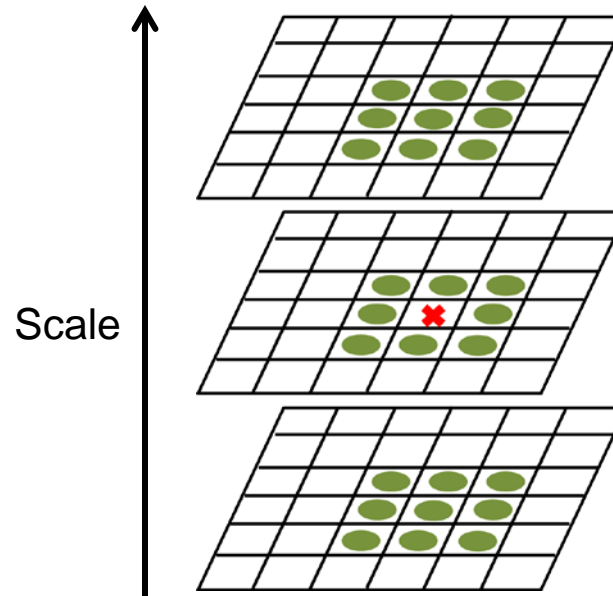
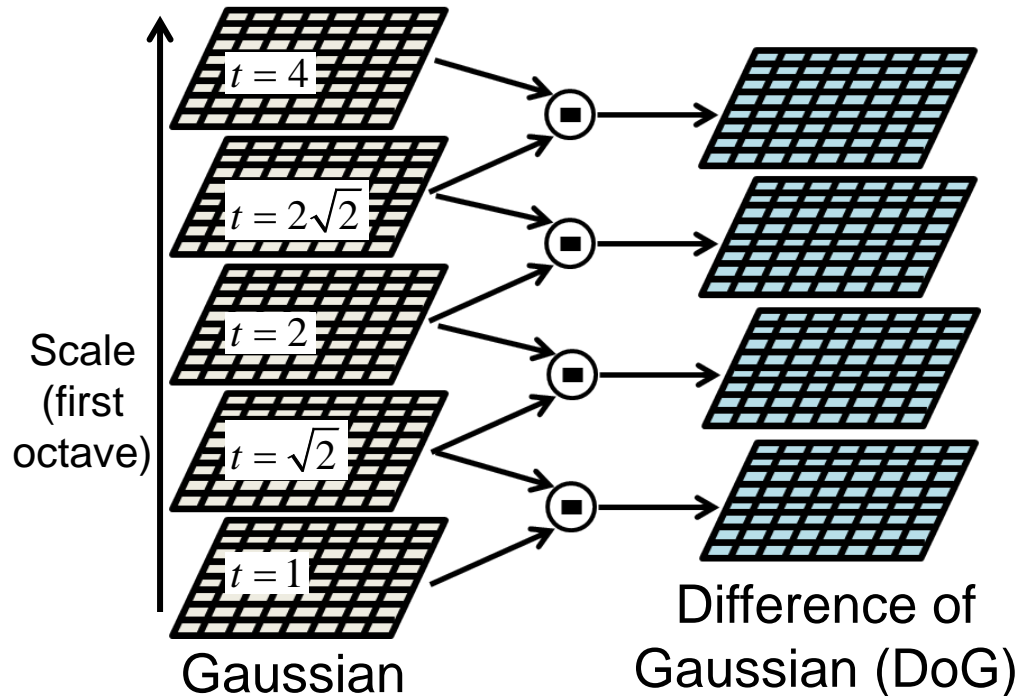

[Lowe, 1999, 2004]

SIFT scale space pyramid: octave 1

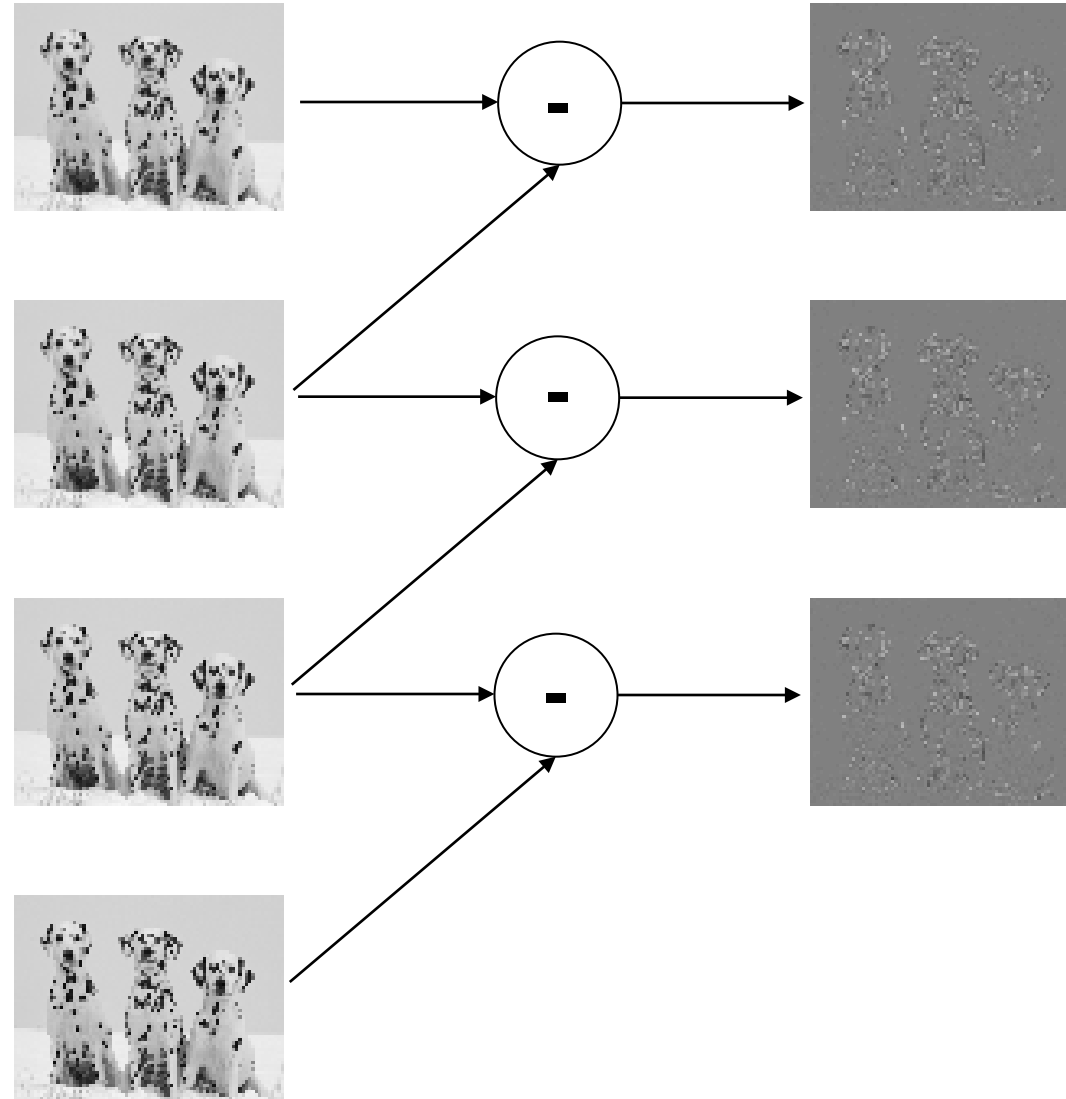

SIFT scale space pyramid: octave 2

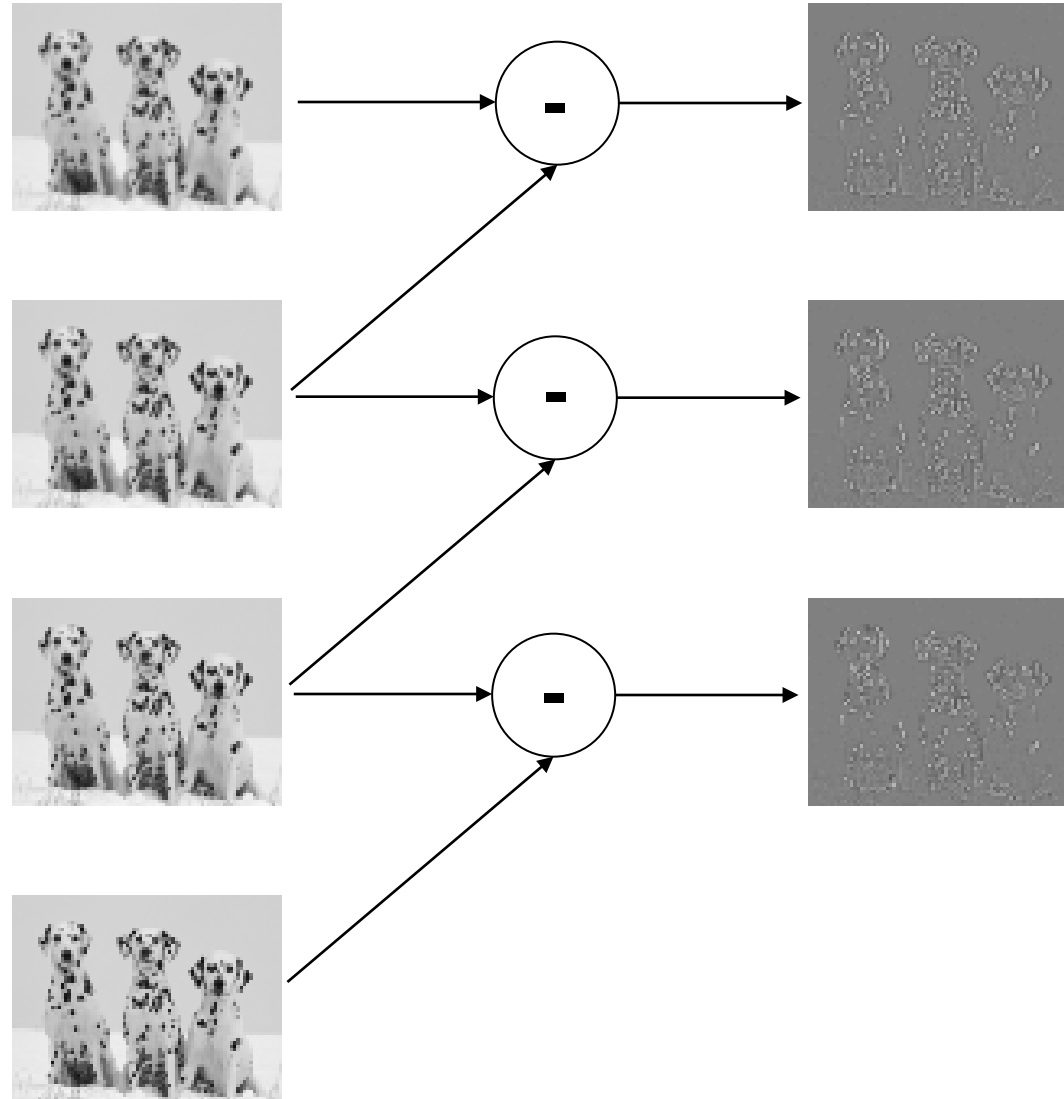

SIFT scale space pyramid: octave 3

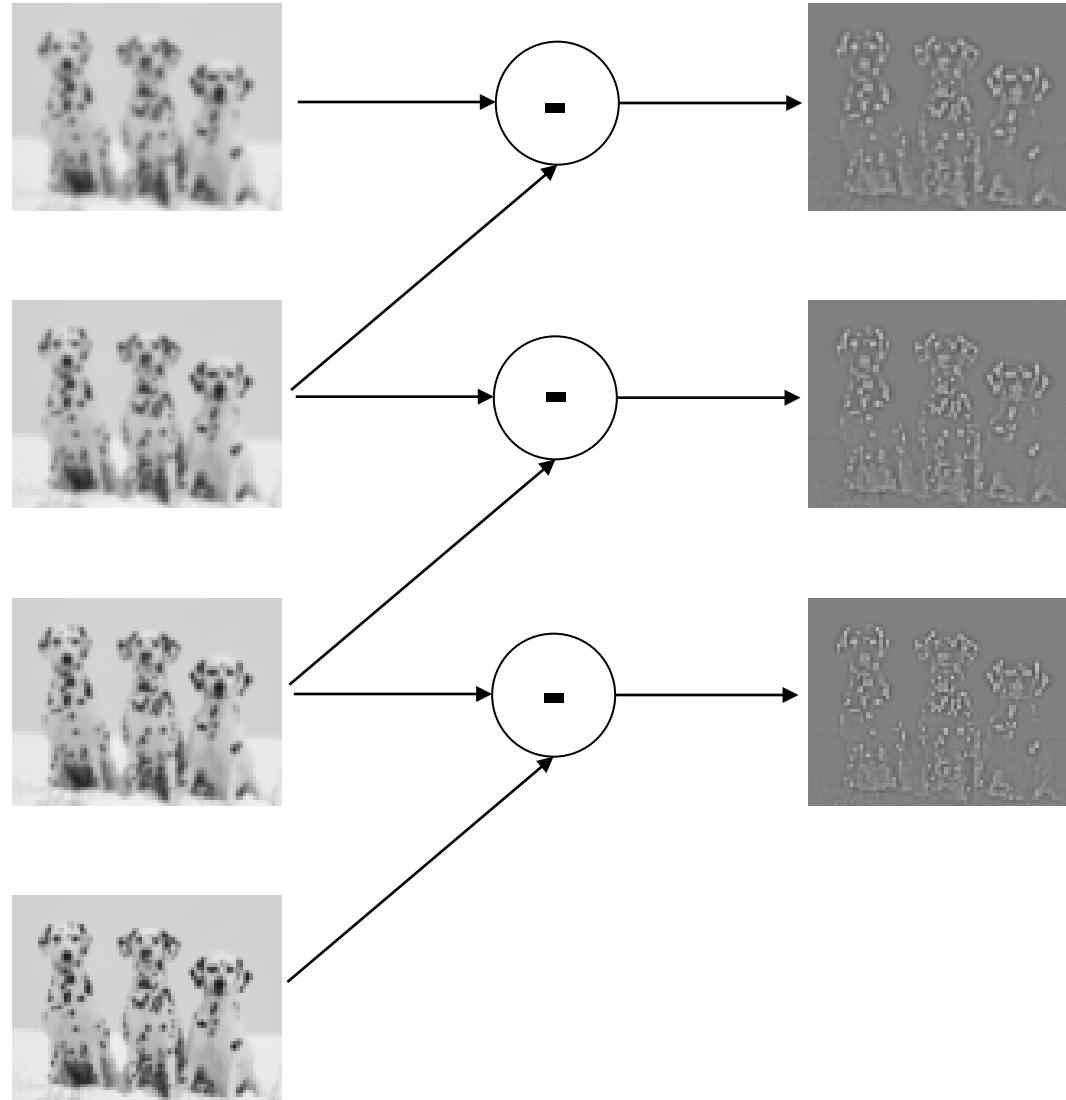

SIFT scale space pyramid: octave 4

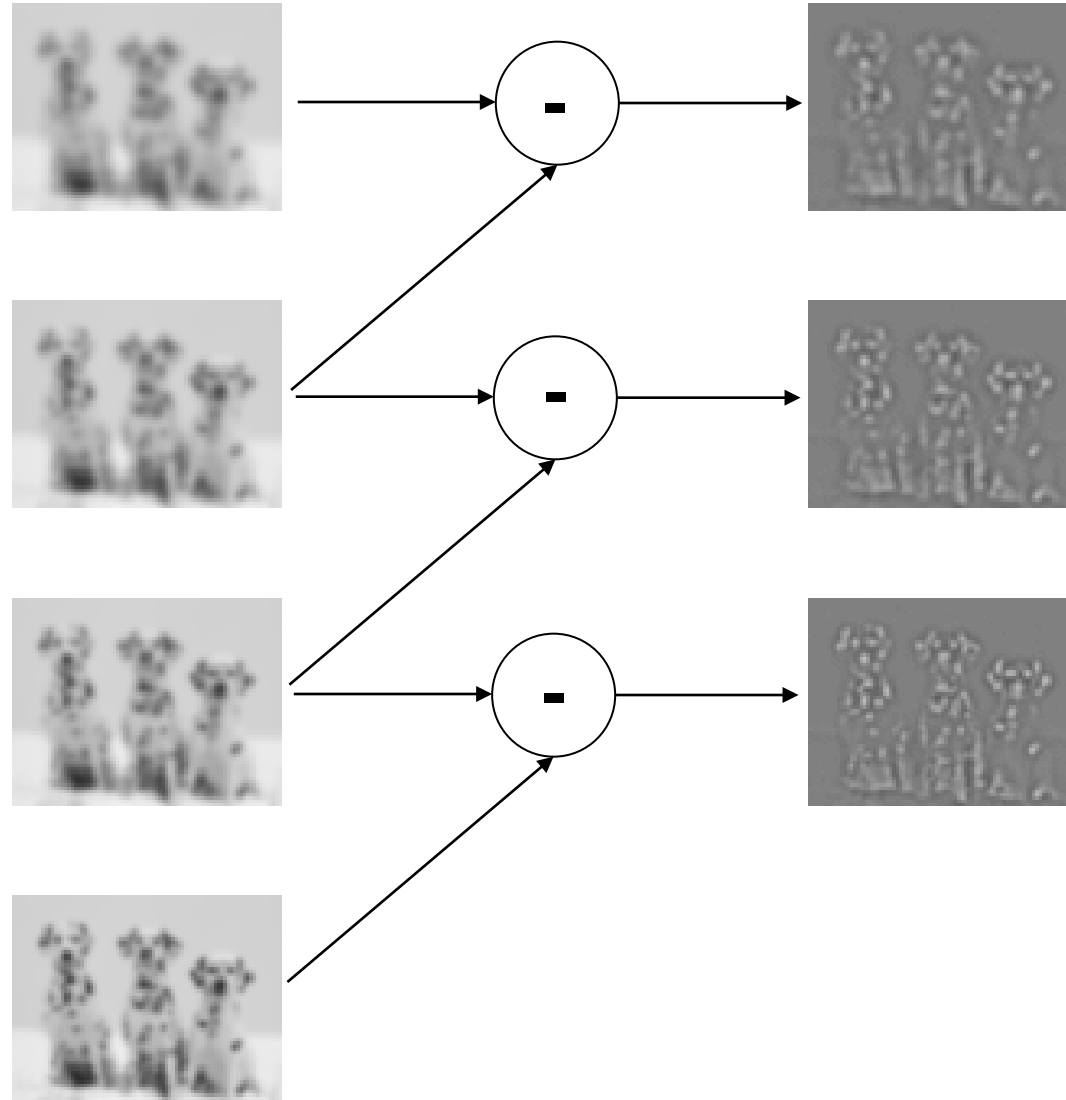

SIFT scale space pyramid: octave 5

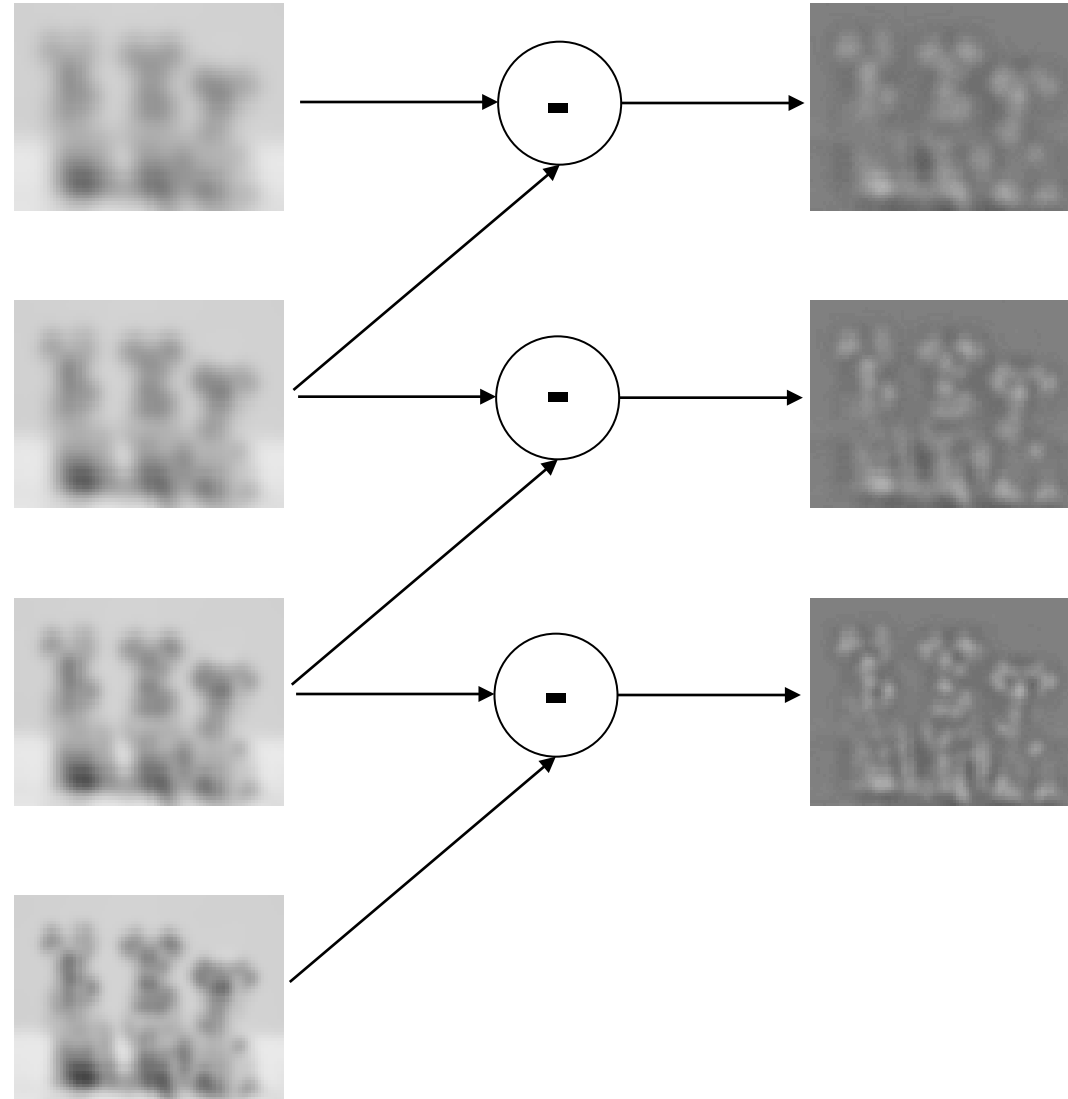

SIFT keypoints



SIFT keypoints



Robustness against scaling

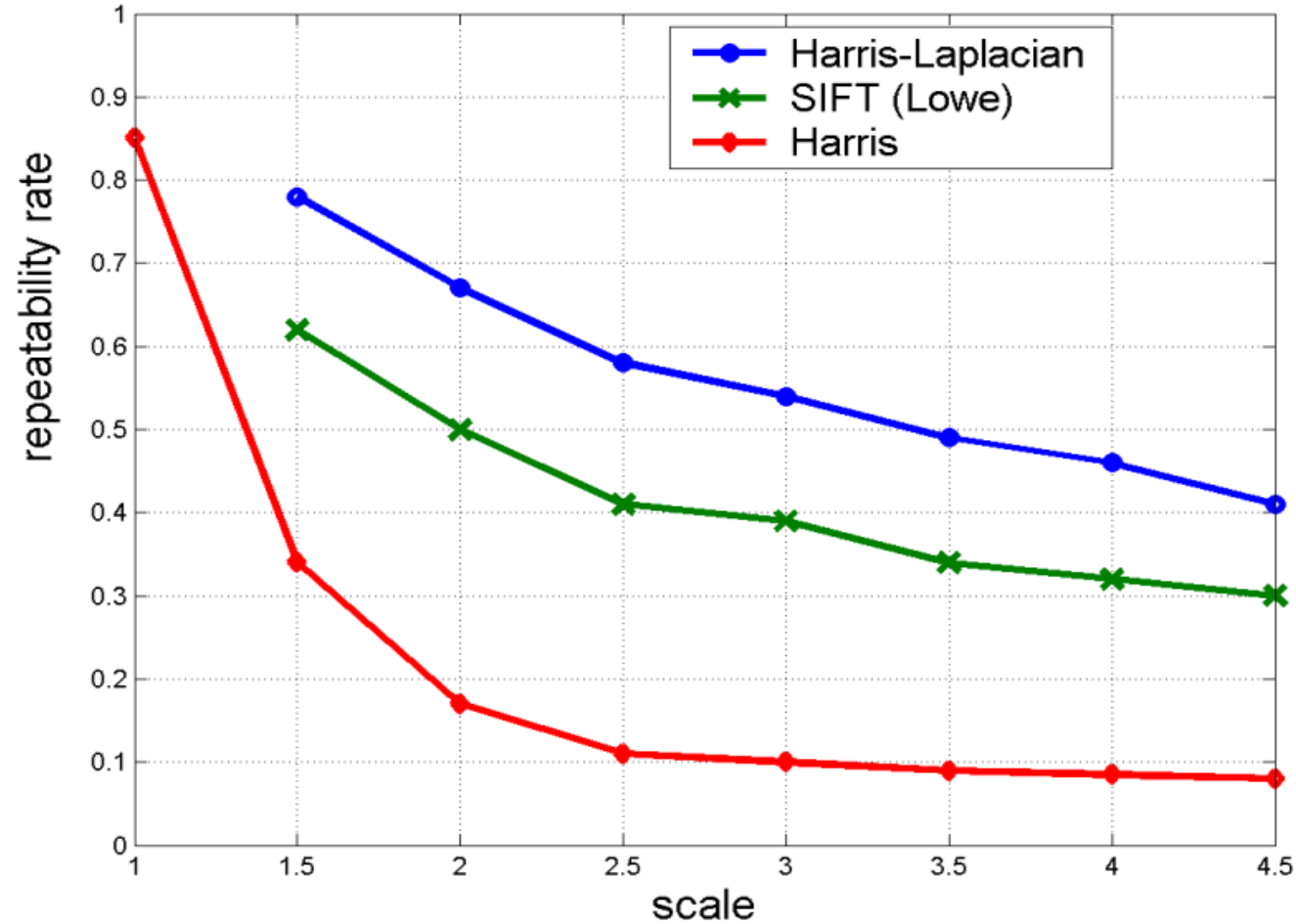

[Mikolajczyk, Schmid, 2001]