

# Keypoint detection

- Many applications benefit from features localized in  $(x,y)$
- Edges well localized only in one direction → detect corners?

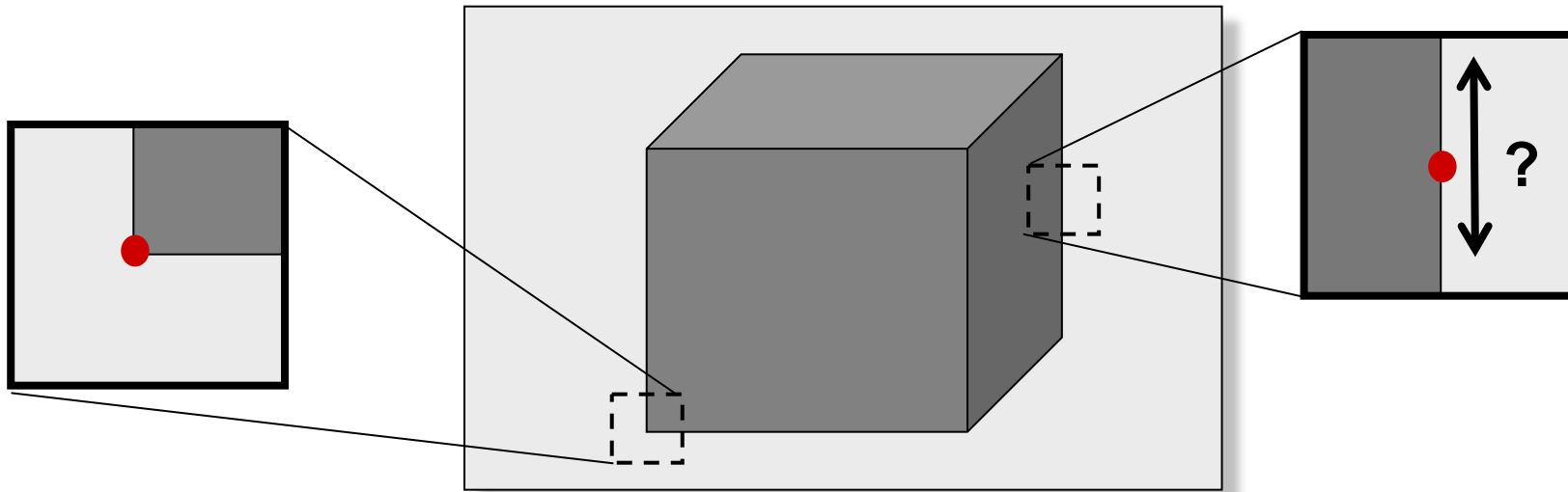

- Desirable properties of keypoint detector
  - Accurate localization
  - Invariance against shift, rotation, scale, brightness change
  - Robustness against noise, high repeatability

# Keypoint detection

- Laplacian detector
- Determinant of Hessian detector
- Harris detector
- FAST detector